



Blue Man Group performs in Las Vegas. Photo by Ken Howard. ©Blue Man Production.

# ALTMAN

theatrical lighting catalog



# Bringing Imagination to Light™

## Table of Contents

Who We Are	1	Scoop Lights	26
Manufacturing	4	Followspot Lights	28
Custom Manufacturing	8	Borderlights	32
Innovations	10	Film & Video Lights	40
Installations	14	Effects Lights	46
Fresnel Lights	16	Distribution	50
Ellipsoidal Lights	18	Accessories	52
PAR Lights	22		

# Altman...

A name that stands for quality, durability, pride, and excellence...  
a name synonymous with tradition, dedication, and design innovation...  
a family name. For over fifty years the Altman™ name has stood true as  
one of the leading innovators of theatrical, architectural, film and video  
lighting available on the market today.

Charles Altman, the patriarch and founder, whose spirit is still alive  
in the company today, founded the company based on the ideals of  
a top quality product available at an affordable price. Ronald Altman,  
whose memory still inspires loyalty and will always live on as the  
company grows. Robert Altman, a son who leads the company  
into the 21st century with state of the art innovations and high  
quality product with his father Charlie's philosophy still in mind.  
Randall Altman, a grandson, who is stride by stride with Robert  
maintaining family pride in excellence. As the generations continue  
through the constant pursuit of excellence, these individuals as well  
as other family members and the complete staff of employees  
(who are all treated as family members) strive to keep the family  
philosophy alive with customer satisfaction, personal service,  
and a quality product that has proved to last through the test of time.



Spectra-CYC 100's at Faith Church, Milford, CT  
Lighting Design by Kris Hodge. Photo by Bob Faubel

Henry Ford once said about family: "Coming together is a beginning.  
Keeping together is progress. Working together is success."

This catalog is dedicated in loving memory of Charlie, Alice, Ronald and  
Victoria Altman. May the wind always be at your back, and the sun  
always upon your face, and may the wings of destiny carry you aloft to  
dance with the stars.

# M

# anufacturing

From receipt of customer order, our experienced customer service representatives process orders into our computer system for scheduled ship dates. Each customer order is analyzed to insure accuracy and customer delivery in a fast accurate manner. Altman Lighting™ manufactures a full standard product line of Theater & Stage, Television & Film, and a large Architectural product line to accommodate every specification. Altman Lighting specializes in custom work which is available in all product lines. All custom work is routed through our engineering department for review of form, fit, and functionality. In most cases prints are computer generated in SolidWorks 3D to aid our technicians in the manufacturing process. Custom work can range from building a specialty lighting fixture to a custom paint application.

Our manufacturing process is driven by real time customer requirements, and directly linked to our computer guided MRP software program which generates work flow throughout our manufacturing plant at different stages. Our warehouse operation controls all raw product materials and inventories, twenty thousand plus component parts at any given time. These parts are grouped and distributed by time sequence to multiple manufacturing work centers for the production process of all products. The first stage of manufacturing starts in our fabrication department which consists of all metal fabrication. All steel and metal parts are processed with state of the art automated Lasers and CNC punching processes.

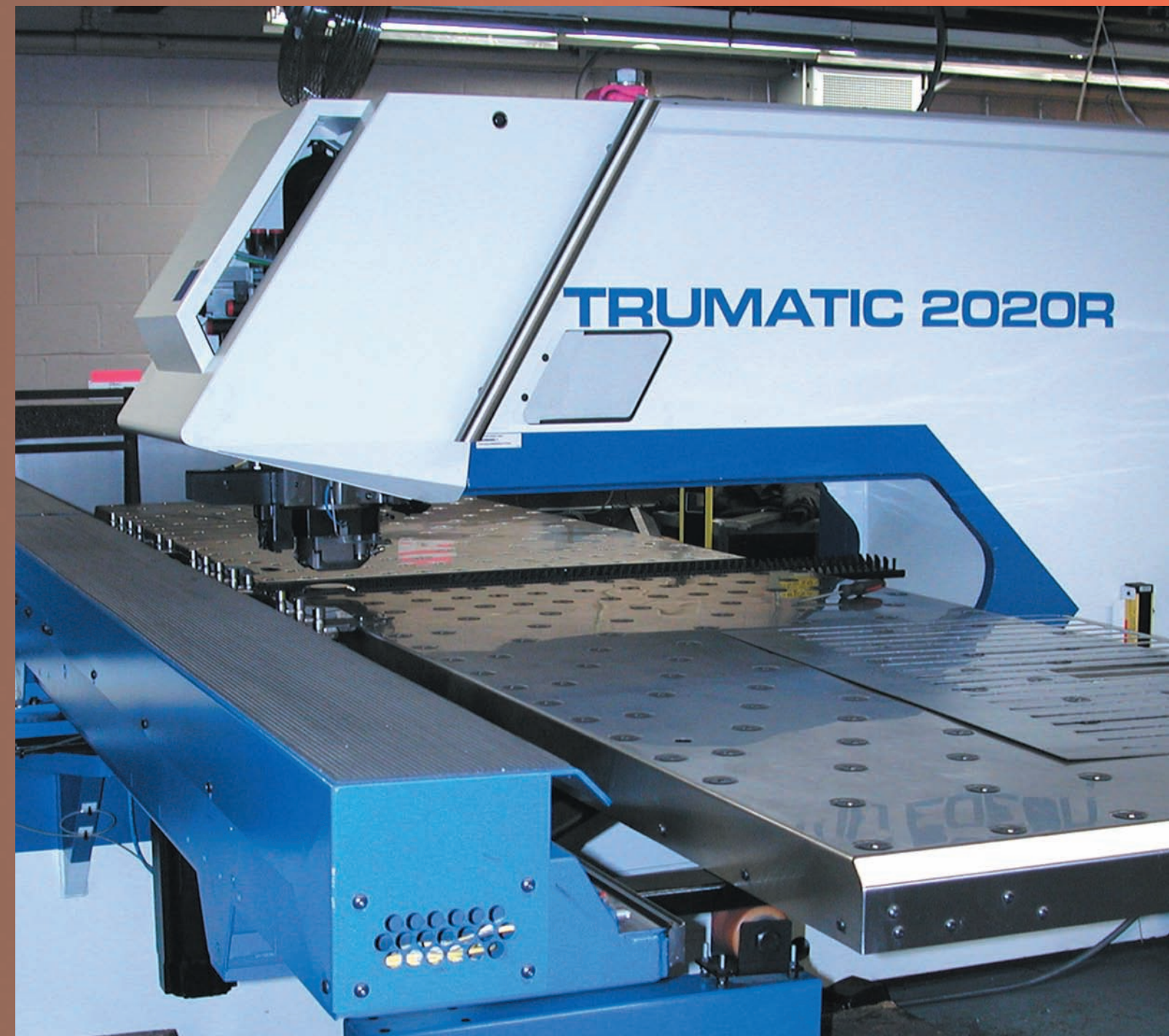

TRUMATIC 2020R Press—a high-precision coordinate-holing sheet-processing center with numerical program control.

## Altman Timeline

For over fifty years the Altman name has stood true as one of the leading innovators of theatrical, architectural, film and video lighting available on the market today.

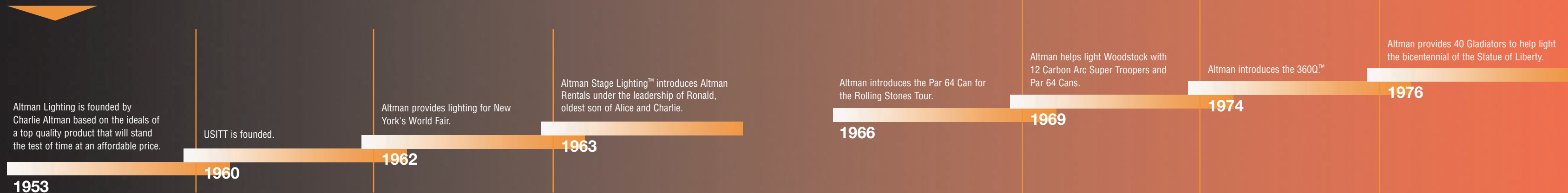

# M

# anufacturing

Once component steel parts are fabricated with all primary and secondary operations they are moved to our electrostatic paint operation. In this department steel surfaces are degreased with a high pressure wash process, baked at a high temperature to dry and painted on an automated conveyor system by the selected production color. This department can produce up to three thousand parts per day of powder coated component parts with a superior paint finish.

Product assembly is the next process where heavy emphasis is placed on quality control. Departmental managers and supervisors oversee the assembly of production runs and are responsible for meeting manufacturing deadlines. Altman Lighting has multiple finished product assembly lines which are defined by product type. Trained technicians at Altman merge electrical components, painted parts and assembly experience creating high quality finished product.

All finished products are tested, labeled and forwarded to our packaging department for the final step in production. Once the finished product is packaged, it is then grouped by customer order or put into one of our many warehouses available for sale to our customers. Customer orders that are scheduled to ship are now packaged and palletized ready for outbound shipment. Based on the shipping method the customers requires, carriers are notified to pick-up the completed orders and shipments that same day will be loaded onto trucks by forklift for shipment. Once customer orders have shipped from our facility, customers are notified by electronic mail with a shipping confirmation providing them all pertinent information required to track their personal order. In addition Altman offers every type of outbound shipping available including freight forwarders for international shipments, air freight, and delivery in the tri-state area by our own fleet of trucks, as well as customer pick-up.



TruLaser 02025—high-speed laser cutting machine.

## Altman Timeline

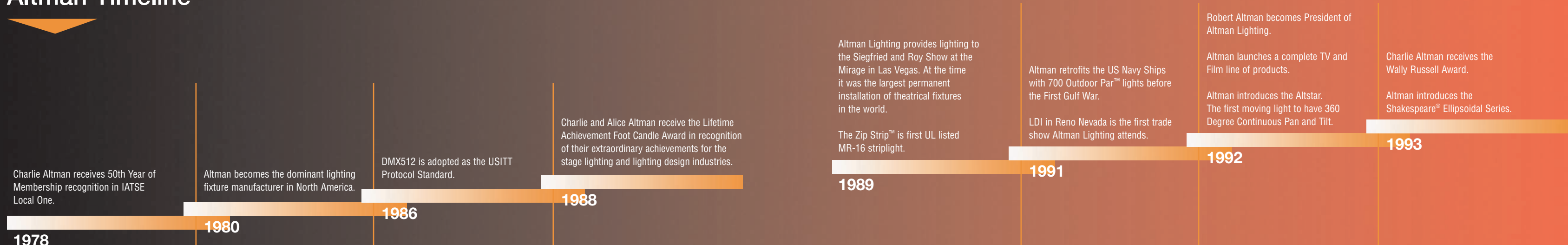

# Custom Manufacturing



Skilled, experienced staff using state-of-the-art equipment assures you of products to meet all your custom lighting needs. Altman controls all processes in-house to meet your exact specifications and requirements. Our design and engineering staff have worked with some of the top lighting designers to create unique luminaires that both enhance and illuminate the environment being shaped.

Our vast experience in producing fixtures ranges from conventional incandescent to LED technology. Our Research and Development team will work with you to find the perfect solution to building an aesthetically pleasing yet ruggedly functional luminaire.



With our state-of-the-art technology for fabrication, bending, and metal cutting, we have the machinery in-house so that we can maintain the tightest of tolerances and present the designer with the physical realization of their most innovative designs.

Utilizing the latest CAD/CAM and CNC technology, with a minimal design to finish time, Altman can insure prompt delivery. For over 50 years, Altman Lighting has known the importance of opening night and we know the importance of your deadline.



## Altman Timeline

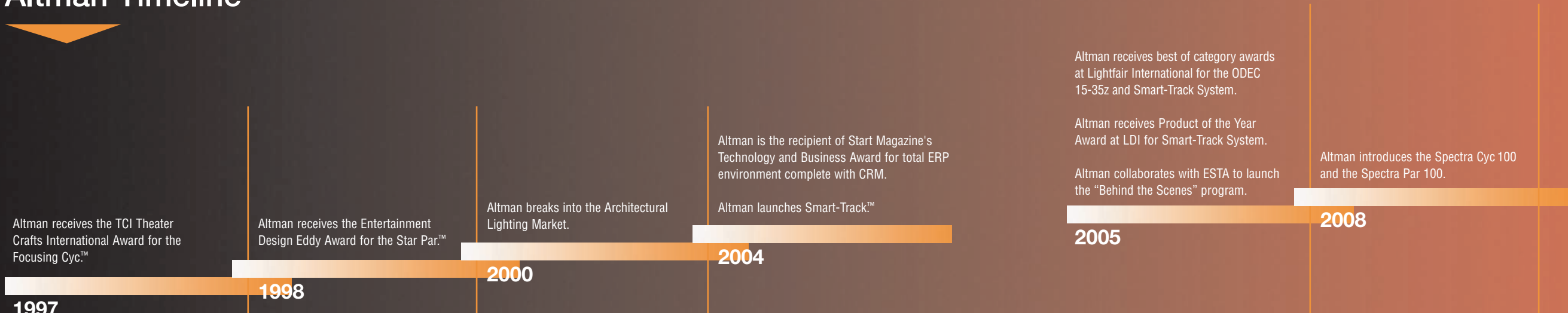

# Innovations

## Smart-Track™

Altman Architectural/Theatrical Smart-Track Lighting System is a revolutionary way to bring digital control signals to addressable architectural/theatrical luminaries without the need for dimmer packs and bulky cable runs.

Altman Smart-Track is easy to lay out, install, and offers you the opportunity to easily create and activate new lighting scenes time after time, all at a cost-effective price. The Smart-Track Lighting System works best with Altman Smart IQseries luminaries. This series includes quartz, CDM, and LED light sources with built-in dimming and control. With Smart-Track, you can dim the quartz lamps; switch the CDM lamps on and off; as well as dim and colormix LED sources. The unique features of Altman Smart-Track system make it the ideal solution for many applications. The system is suitable for retail stores, museums, churches, restaurants, clubs, and so much more. The range of applications for Altman Smart-Track is as varied as the looks the system makes possible.



Las Vegas Natural History Museum. Lighting Designer Marc Rosenberg, CD + M Design. Photo by Michael Tucker.

### Smart-Track Lighting System

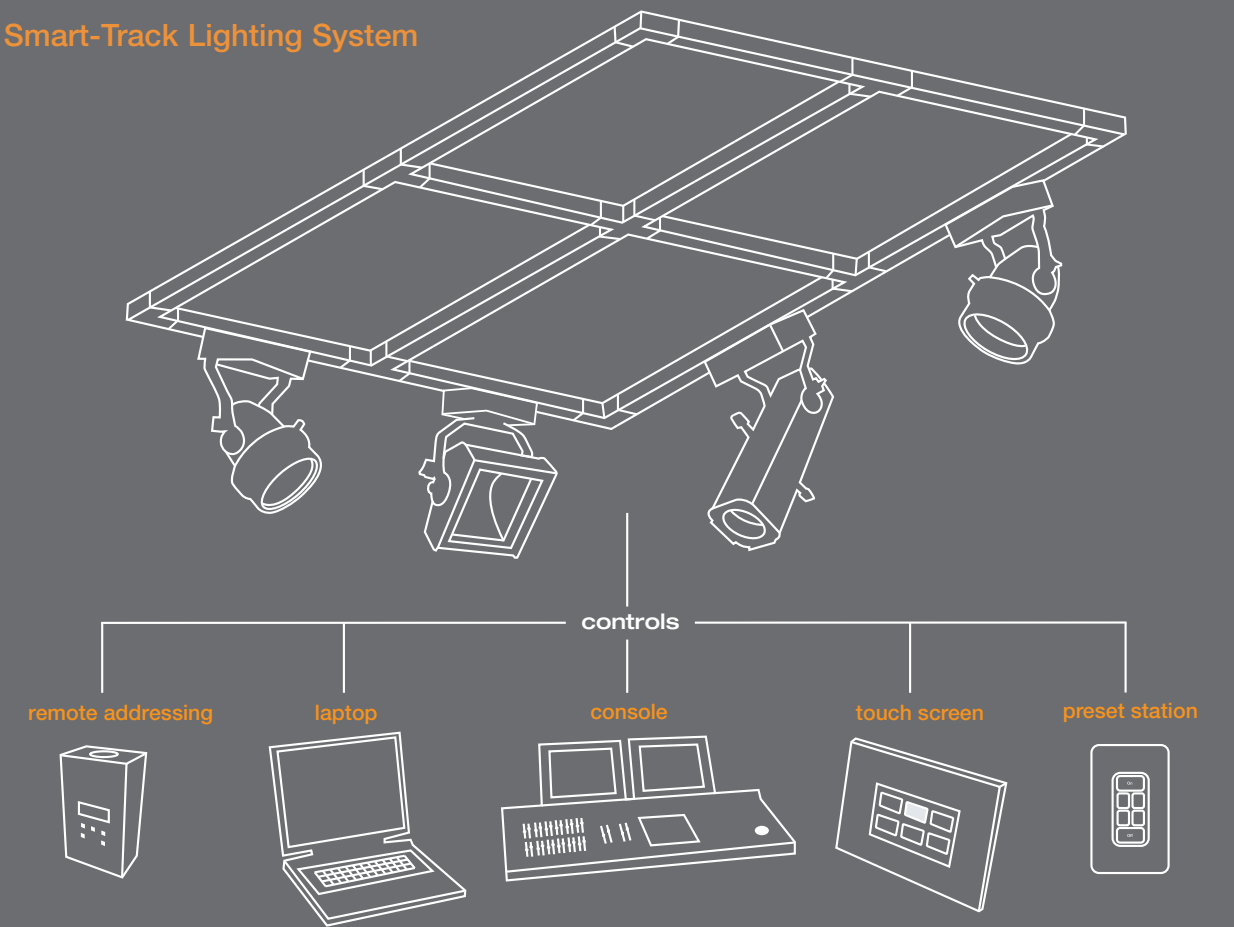

Smart-Track is a comprehensive system of components that offers innovative solutions for transporting control signals as well as power to individual luminaries. Whether using simple architectural control stations; a laptop; or a DMX-based theatrical lighting console, you are in control with Smart-Track.

This heavy-duty extruded aluminum track is ideal for demanding applications where a low-profile look is desired but numerous luminaries are needed.

For total flexibility, you can choose your protocol. Smart-Track is compatible with DMX and RDM (Remote Device Management). It also can be integrated into existing systems to easily expand to a new design. By including the digital control signal in the track, the Smart-Track system allows dimming, switching, and effects to be obtained when using Altman Smart IQseries

of luminaries. With quartz and CDM luminaries with on-board dimming or control, as well as Altman Spectraseries LED architectural luminaries for color mixing, the possibilities are endless.

The Altman Smart IQseries luminaries retain their identity and programming, even when moved to a new location. The designer can individually control each luminaire hung on the track system.

Automated luminaries as well as DMX accessories may be controlled all from the Smart-Track system as well by using the DMX outlet adapter to break DMX out of the track. Maximum control and reduced energy costs make Altman Smart-Track lighting system the innovative solution for any application.

# Innovations

## LED Lights

### 100 WATT SPECTRA-CYC LED Catalog #: SS-CYC-100

The Spectra Cyc is a 100 Watt cyclorama/wall wash luminaire utilizing red, green, blue and amber LED emitters. Designed for theatrical and architectural applications, the Spectra Cyc blends colors via a patent pending LED lens which reduces pixelization from direct view. The on board power supply allows for direct power & data input which can be daisy chained thru 10 units. Designed for use on 4-6' centers, individual units can be linked side by side for greater saturation of light.

The Spectra Cyc is compatible with both DMX and RDM protocols, and comes complete with a library of pre-programmed single colors and various color mixes. Units are made for floor or sky-cyc applications.



SS-CYC-100

#### Features:

- Red, Green, Blue & Amber 3 Watt Luxeon Rebel LED's
- Patent Pending LED lens
- On board power supply
- Feed thru power & data capabilities
- Compatible with DMX and RDM protocols
- Push button addressing
- Pre-programmed modes
- Light weight aluminum housing
- E.T.L. & c.E.T.L.
- Made in the USA

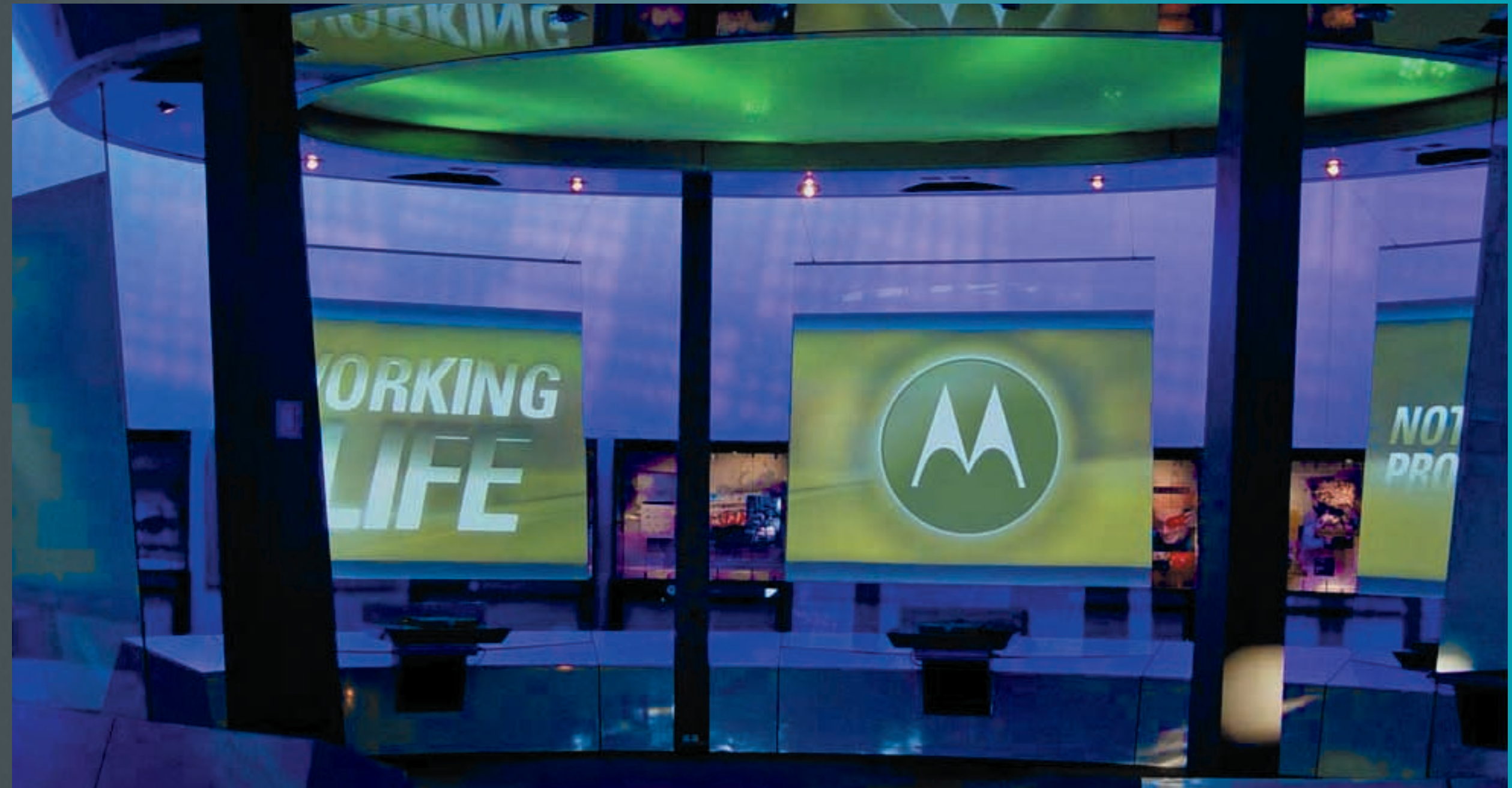

Lighting design by Michael Stiller Design. Exhibit design by M. Photo by Michael Stiller.

### 100 WATT SPECTRA PAR 100 LED Catalog #: SS-PAR-100

The SPECTRA PAR 100 is a 100 Watt par luminaire utilizing red, green, blue and amber LED emitters. Designed for theatrical and architectural applications, the SPECTRA PAR 100 acts as a true par lighting fixture complete with interchangeable VNSP, NSP, MFL and WFL lenses.

The on board power supply allows for direct power input. Data can be easily daisy chained for up to 1000 feet. The SPECTRA PAR 100 is compatible with both DMX and RDM protocols, and comes complete with a library of pre-programmed single colors and various color mixes.

#### Features:

- Red, Green, Blue & Amber 3 Watt Luxeon Rebel LED's
- Interchangeable VNSP, NSP, MFL and WFL lenses
- On board power supply
- Feed thru data capabilities
- Compatible with DMX and RDM protocols
- Push button addressing
- Pre-programmed modes
- Die Cast aluminum housing
- E.T.L. & c.E.T.L.
- Made in the USA



SS-PAR-100



# Installations

## Focus on Lighting

For over 50 years, Altman has supported designers by giving them the means to express their vision in a realized form. We have a long track record of taking the wildest flights of fancy and producing everything from one-offs to complete product lines. A designed mix of our stock product with our custom work helps the designer shape the environment they desire.

Strong design is made even better when it is supported by complementary lighting. It is the right equipment solutions that reveal the design, whether the concept emphasizes functionality or form, often the lighting must accomplish both.

Whether you are looking for an overall ambient lighting design, or one that dramatically highlights the space; no matter if it is form or function, we can provide you with the proper tools to make your design work.

Light can help define a space as well as set the mood. By placing the light in just the right place; shaping the beam

of light—controlling the light—you can highlight that feature, give focus and direct the viewers eye where you want it to go. With the right choice of color in the light you can create a positive environment as well as influence a person's mood.

The ability to control the environment with lighting requires the designer to establish both the required ambient light needed as well as the desired shifts in mood that the viewer should be moved through in the course of the experience.

Carefully chosen and focused light brings the set out of darkness to direct attention towards the essential elements. The lighting draws the viewer through the experience by specific use of both focus and color.

We have worked with lighting designers from all backgrounds and experiences—architectural, theatrical, television and film, concerts, theme parks, and museums. This knowledge helps us improve our products to offer cost-effective solutions.



Blue Man Group performs in Las Vegas. Photo by Paula Wilson. ©Blue Man Production.

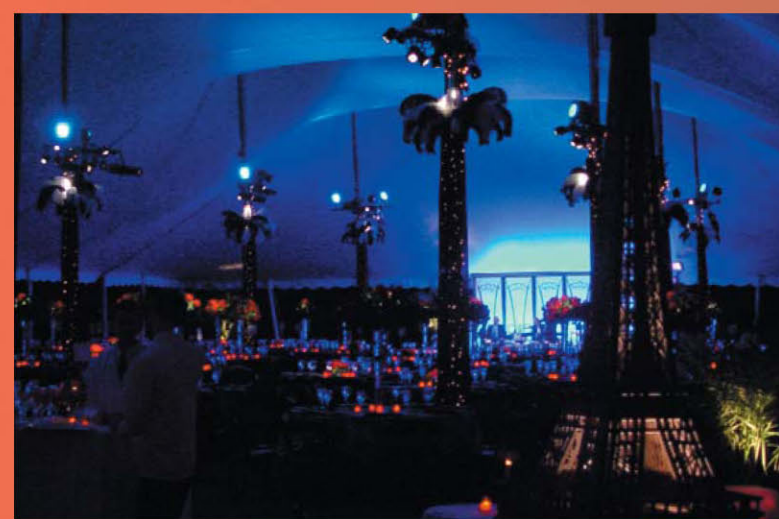

The Caramoor Gala in Bedford, NY. The lighting design and photo by Pete Petrino.



FaithChurch, Milford, CT. Lighting Designer Kris Hodge. Photo by Bob Faubel.



Howard Stern Show. Lighting designer Dave Feldmen. Photo by Scott DePace.



Travco Group Egypt. Architect Adel Halim Salama. Lighting Designer Hatem Habashi. Photo by Hatem Habashi.

## Model: 100 Watt 3" Fresnel Catalog #: 100

A lightweight, very short throw, all purpose lighting device; the 100 produces a soft-edged beam which varies in diameter from 4.2 feet to 10.4 feet at a throw distance of 10 feet. The 100 is designed for incandescent lamps as well as tungsten halogen lamps. The unit is used in theater for specials or in television and photographic studios for tabletop applications. Other uses include nightclubs, museums and show windows where soft-edged controlled lighting is required.

Max Wattage ..... 100 watts  
Voltage .... 120/240 Volts AC/DC, .83/4.2 amps  
Dimensions (in) ..... 5.25W x 7.5H x 4.25D  
Dimensions (cm) ..... 13W x 19H x 11D  
Weight ..... 2.2 lbs. (.99 kg)



### 100 Photometric Data for ESR Lamp

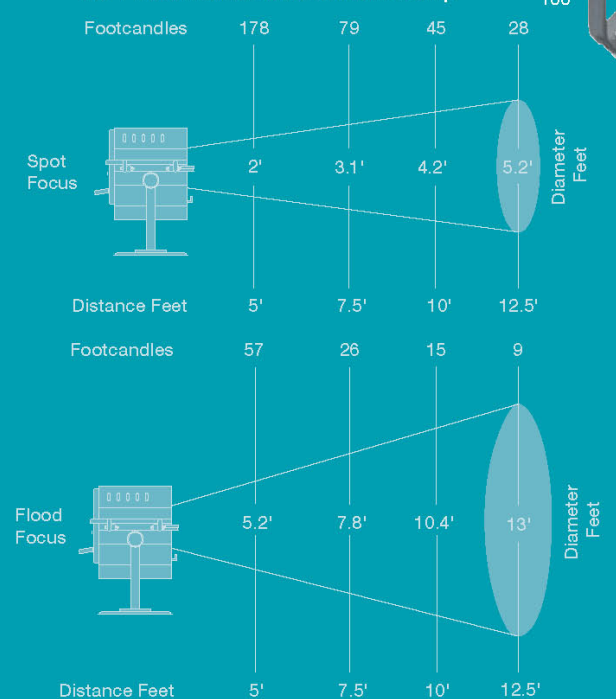

# Fresnel lighting



## Model: 1000 Watt 6" Die-Cast Fresnel Catalog #: 1KAF-MPF, 1KAF-MBP

A basic set lighting device for stage, studio and television; the 1KAF produces a soft-edged beam which varies in diameter from 5.7 feet to 39 feet at a throw distance of 25 feet. The 1KAF is designed for operation with long life, high intensity, tungsten halogen lamps, with either medium bi-post or prefocus bases. The luminaire is used in theatre for acting area lighting where beam shaping is not required, or in the studio as a key-light or backlight when a smooth even beam is required. Constructed of cast aluminum and designed to withstand tramping, the 1KAF is also used in nightclubs, museums and show rooms where high intensity, soft-edged controlled lighting is required.

Max Wattage ..... 1000 watts  
Voltage ..... 120/240 Volts AC/DC, 8.3/4.2 amps  
Dimensions (in) ..... 10.25W x 16.625H x 12.5D  
Dimensions (cm) ..... 26W x 42H x 32D  
Weight ..... 10.25 lbs. (4.61 kg)

1KAF-MPF  
1KAF-MBP



### 1KAF-MBP Photometric Data for EGT Lamp

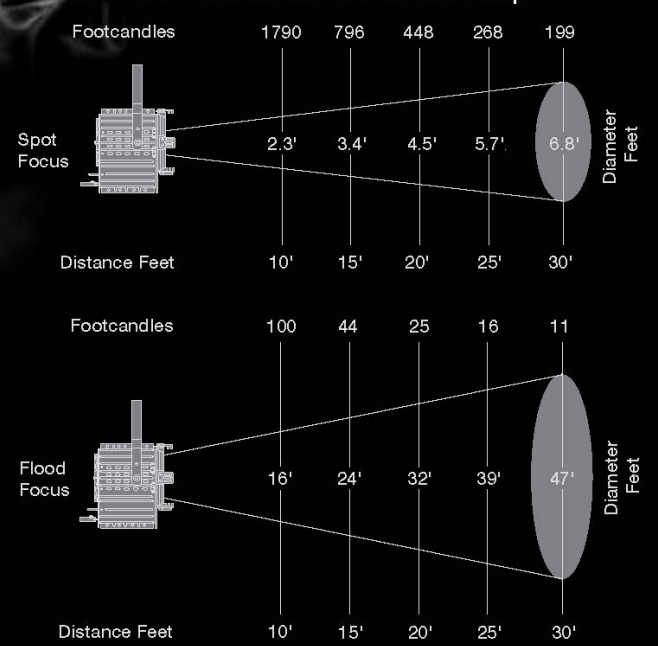

### 1KAF-MPF Photometric Data for BTR Lamp

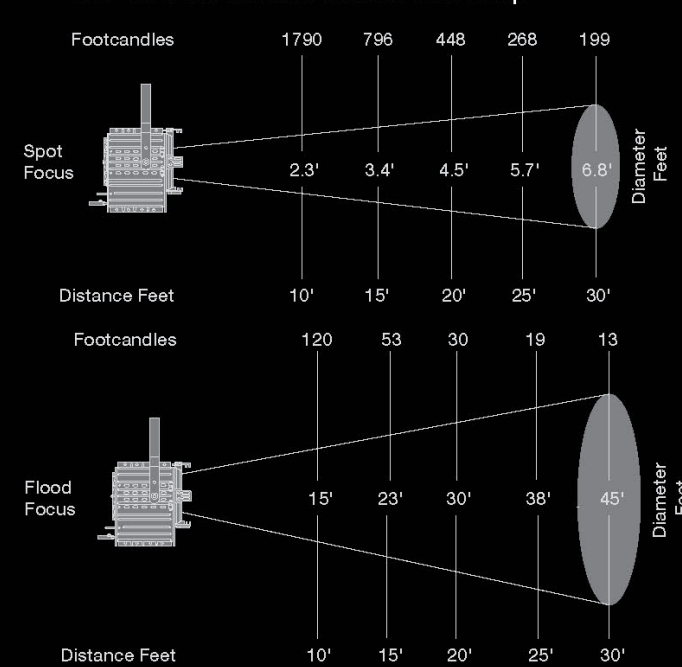

## Model: 750 Watt 6" Fresnel Catalog #: 65Q, 165Q

A lightweight, short-throw, all purpose lighting device, the 6" fresnel produces a soft-edged beam varying in diameter from 4.2 feet to 21 feet at a throw distance of 15 feet. The 65Q and 165Q are designed for operation with long-life, high-intensity tungsten-halogen lamps. The luminaire is used in theatre for acting area lighting where beam shaping is not required, or in television studios for key and back lighting. Other uses include is nightclubs, museums and show windows where soft edge controlled lighting is required.



Max Wattage ..... 750 watts  
Voltage ..... 120/240 Volts AC/DC, 6.3/3.1 amps  
Dimensions for 65Q (in) ..... 8.25W x 13.75H x 8.75D  
Dimensions for 65Q (cm) ..... 21W x 35H x 22D  
Dimensions for 165Q (in) ..... 8.5W x 14.25H x 10.25D  
Dimensions for 165Q (cm) ..... 21.6W x 37H x 26D  
Weight for 65Q ..... 9 lbs. (4.1 kg)  
Weight for 165Q ..... 10.5 lbs. (4.7 kg)

### 65Q Photometric Data with BTN Lamp

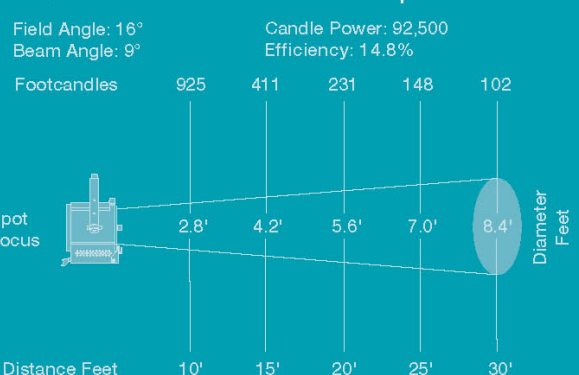

### 165Q Photometric Data with BTN Lamp

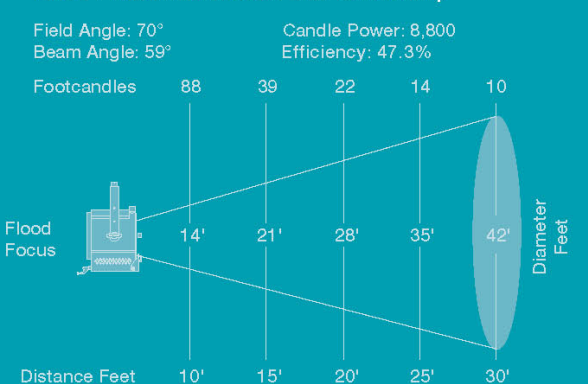

## Model: 1000 Watt 8" Fresnel Catalog #: 75Q, 175Q

A lightweight, long throw, all-purpose lighting device the 8" fresnel produces a soft-edged beam which varies in diameter from 6.3 feet to 25 feet at a throw distance of 30 feet for the 75Q. The 75Q is designed for operation with the long life, high intensity tungsten halogen lamps. The luminaire is used in theatre for acting area lighting where beam shaping is not required or in television studios for key and backlighting. Other uses include nightclubs, museums and show windows where soft edge controlled lighting is required.

Max Wattage ..... 1000 watts  
Voltage ..... 120/240 Volts AC/DC, 8.3/4.2 amps  
Dimensions for 75Q (in) ..... 11.25W x 18H x 11D  
Dimensions for 75Q (cm) ..... 28.6W x 46H x 28D  
Dimensions for 175Q (in) ..... 11.25W x 19H x 13.5D  
Dimensions for 175Q (cm) ..... 28.6W x 48H x 34D  
Weight for 75Q ..... 14.5 lbs. (6.5 kg)  
Weight for 175Q ..... 15 lbs. (6.75 kg)

### 75Q/175Q Photometric Data for BVT Lamp

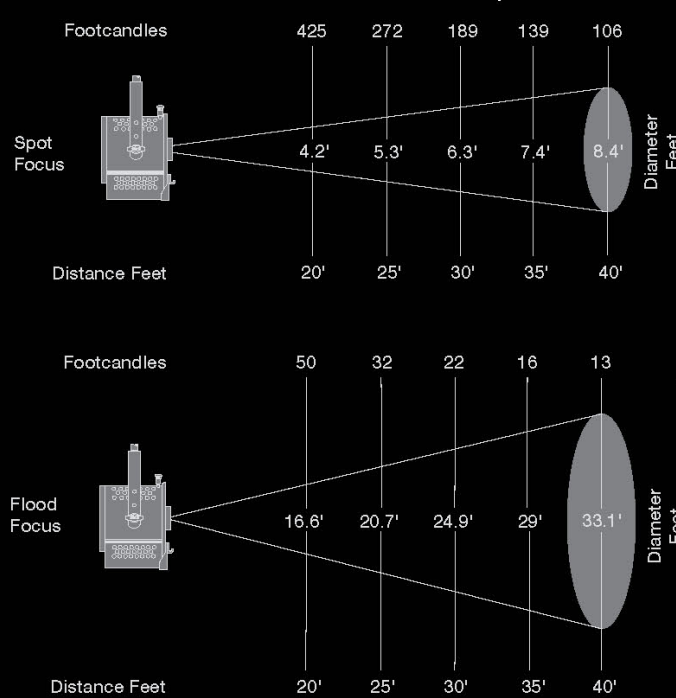

**500 Watt 3.5" Ellipsoidal**  
**Catalog #: 3.5Q-5MT, 3.5Q-6-MT**  
**3.5Q-8-MT, 3.5Q-10-MT, and 3.5Q-12-MT**

A compact, lightweight ellipsoidal spotlight which produces a high intensity sharp or soft-edged beam. Four adjustable integral stainless steel framing shutters provide beam shaping ability and the pattern slot and holder provide the ability to project visual images via steel patterns. While primarily designed for theatre and studio applications, the 3.5Q Series is also useful in displays, show windows, museums and nightclubs where precision controlled accenting is desirable.

Max Wattage	500 watts
Voltage	120/240 Volts AC/DC, 4.2/2.1 amps
Dimensions for 3.5Q-5-MT & 3.5Q-8-MT (in)	9W x 13.5H x 15.5D
Dimensions for 3.5Q-5-MT & 3.5Q-8-MT (cm)	23W x 34H x 39D
Dimensions for 3.5Q-6-MT (in)	9W x 13.5H x 14.325D
Dimensions for 3.5Q-6-MT (cm)	23W x 34H x 33D
Dimensions for 3.5Q-10-MT (in)	9W x 13.5H x 16D
Dimensions for 3.5Q-10-MT (cm)	23W x 34H x 41D
Dimensions for 3.5Q-12-MT (in)	9W x 13.5H x 16.875D
Dimensions for 3.5Q-12-MT (cm)	23W x 34H x 43D
Weight	9 lbs. (4.8 kg)



3.5Q-5MT

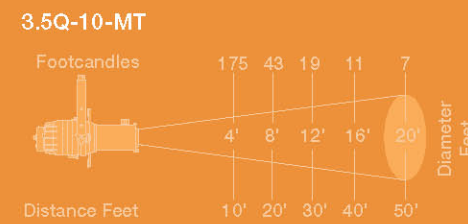
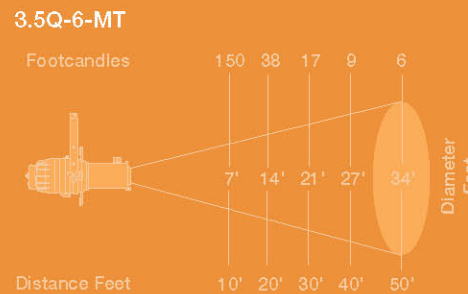
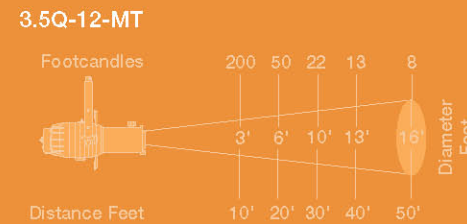
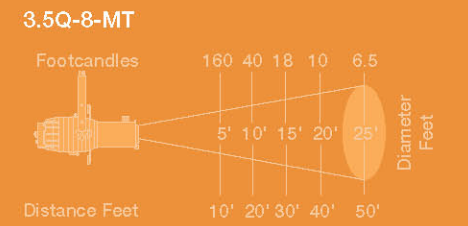
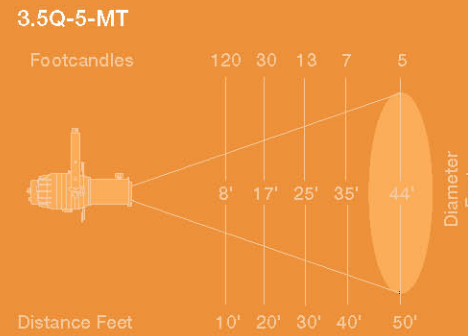

# Ellipsoidal lighting



**750 Watt 360Q 6" Ellipsoidal Axially Mounted Quartz**  
**Catalog #: 360Q 4.5x6.5, 360Q 6x9, 360Q 6x12, 360Q 6x16, 360Q 6x22**

The legendary 360Q is a compact, rugged ellipsoidal spotlight which produces a high intensity sharp or soft-edged beam. This lightweight luminaire is outfitted with an efficient; especially faceted reflector specifically designed for the new generation of 75-watt tungsten halogen lamps. The reflector has over 700 mirror polished surfaces which optimize the optical system for greater light output and a sharper, more controlled focus. Four adjustable integral stainless steel framing shutters provide beam shaping ability and the pattern slot and holder provide the ability to project visual images via steel patterns. While primarily designed for theatre and studio applications, the 360Q Series is also useful in displays, show windows, museums and nightclubs where precision controlled accenting is desirable.

Max Wattage	750 watts	Dimensions for 360Q 6x16 (in)	13W x 16.25H x 22.625D
Voltage	120/240 Volts AC/DC, 6.3/3.1 amps	Dimensions for 360Q 6x16 (cm)	33W x 41H x 57D
Dimensions for 360Q 4.5x6.5 & 6x16 (in)	13W x 16.25H x 18.125D	Dimensions for 360Q 6x22 (in)	13W x 16.25H x 30.5D
Dimensions for 360Q 4.5x6.5 & 6x16 (cm)	33W x 41H x 42D	Dimensions for 360Q 6x22 (cm)	33W x 41H x 77D
Dimensions for 360Q 6x12 (in)	13W x 16.25H x 20.125D	Weight for 360Q 4.5x6.5	13.5 lbs. (6.1 kg)
Dimensions for 360Q 6x12 (cm)	33W x 41H x 51D	Weight for 360Q 6x9	14 lbs. (6.15 kg)
		Weight for 360Q 6x12, 360Q 6x16	15 lbs. (6.75 kg)
		Weight for 360Q 6x22	15 lbs. (6.75 kg)



360Q

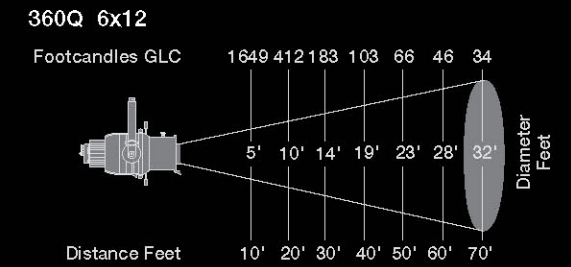
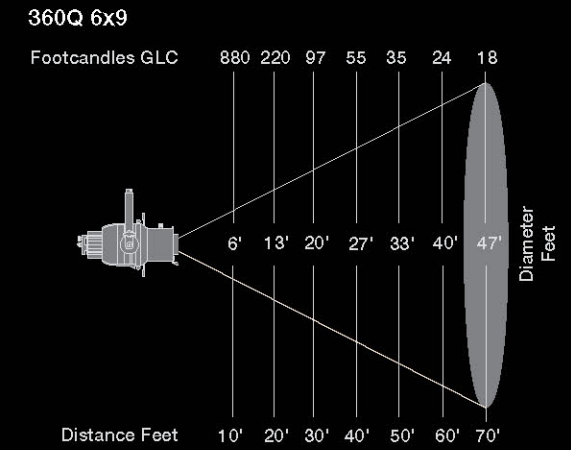
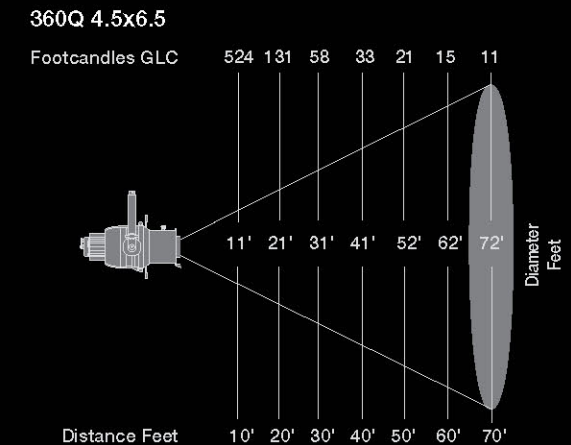
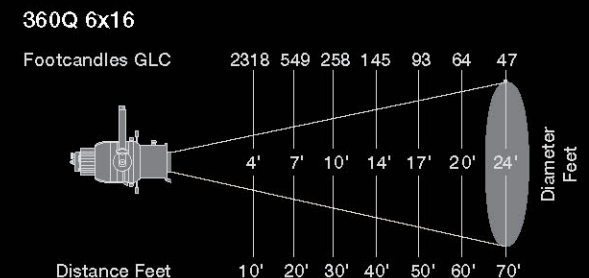
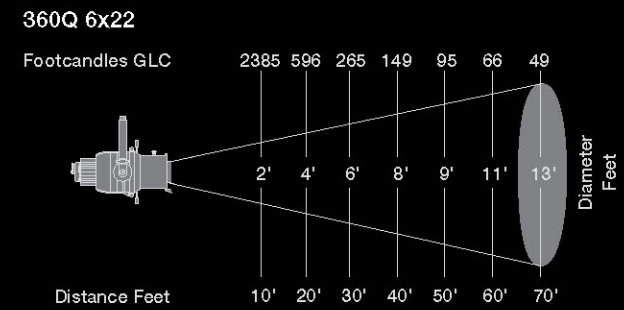

# Ellipsoidal lighting

**750 Shakespeare® Series  
ZOOM Ellipsoidal**  
Catalog #: S6-1535Z, S6-3055Z

The SHAKESPEARE Series Zoom ellipsoidals are the state of the art in variable focus theatrical luminaires for function, style, and efficiency. These ellipsoidals have been designed and engineered with a number of innovative details and features enhancing versatility and efficiency without sacrificing performance. The dichroic coated glass reflector removes heat from the beam, resulting in longer gel and pattern life. The super smooth, variable focus lens system, which operates with Teflon bearings on stainless steel guide rails, produces wide-to-narrow beams offering a sharp, full field and distortion free pattern projection. The generous accessory slot, the two-slot accessory holder, and self-closing, self-locking retaining latch for the accessory holder are just some of the special features provided. The aesthetic appearance and ergonomically designed function controls only add to its appeal. With a wide range of non-proprietary lamps to choose from, the low wattage, high output SHAKESPEARE Zooms are ideal for theatres, nightclubs, television studios, or wherever superior, energy efficient lighting performance is required.

Max Wattage ..... 750 watts  
Voltage ..... 120/240 Volts AC/DC, 6.3/3.1 amps  
Dimensions for S6-3055Z (in) ..... 12W x 17H x 24.75D  
Dimensions for S6-3055Z (cm) ..... 30W x 43H x 63D  
Weight for S6-1535Z ..... 22 lbs. (9.9 kg)  
Weight for S6-3055Z ..... 21 lbs. (9.5 kg)



S6 ZOOM

## 750 Watt Shakespeare® Ellipsoidal

Catalog #: S6-5, S6-10, S6-20, S6-30, S6-40 and S6-50

The 5°, 10°, 20°, 30°, 40° and 50° fixed focus SHAKESPEARE ellipsoidals are state of the art luminaires in function, style, and efficiency. These ellipsoidals have been designed and engineered with a number of innovative details and features enhancing versatility and efficiency without sacrificing performance. The dichroic coated glass reflector removes heat from the beam, resulting in longer gel and pattern life while offering a sharp, full field and distortion free pattern projection. The generous accessory slot, the lens barrel, and the two slot accessory holder (20°, 30°, 40°, and 50° only) all rotate to make these spotlights truly versatile performers, especially when you consider that the lens barrels are completely interchangeable. The self-closing, self-locking retaining latches for the accessory holder, and the secondary lens barrel-retaining latch are just some of the safety features provided. With a wide range of non-proprietary lamps to choose from, the low-wattage, high output SHAKESPEARE ellipsoidal are ideal for theatres, night clubs, television studios, or wherever superior, energy-efficient lighting performance is required.

Max Wattage ..... 750 watts  
Voltage ..... 120/240 Volts AC/DC, 6.3/3.1 amps

Dimensions for Shakespeare S6-10  
Dimensions (in) ..... 12.5W x 17.25H x 31.5D  
Dimensions (cm) ..... 32W x 44H x 80D  
Weight for S6-5 ..... 20 lbs. (9 kg)  
Weight for S6-20 ..... 19 lbs. (8.6 kg)  
Weight for S6-40, S6-10, S6-30, S6-50 ..... 18 lbs. (8.1 kg)

### Photometric Data for GLC Lamp

#### S6-5

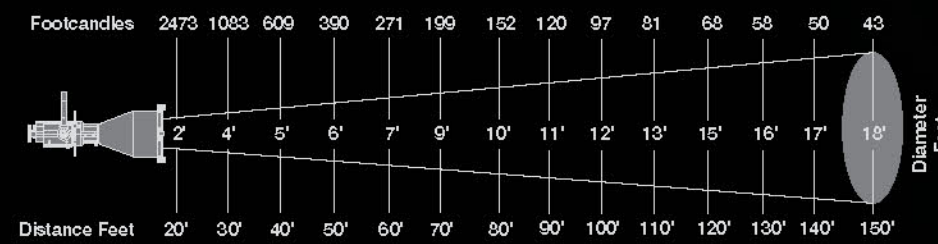

#### S6-10

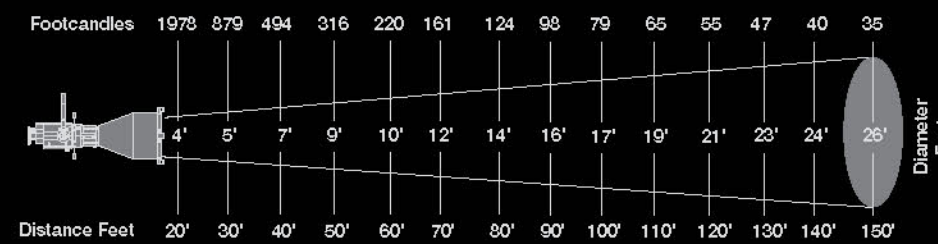

#### S6-20

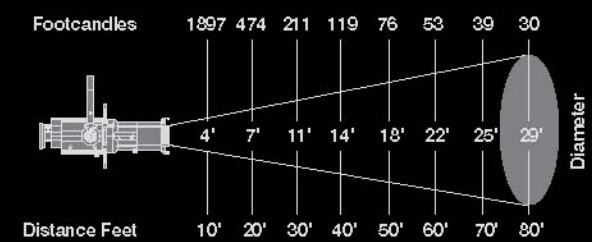

#### S6-40

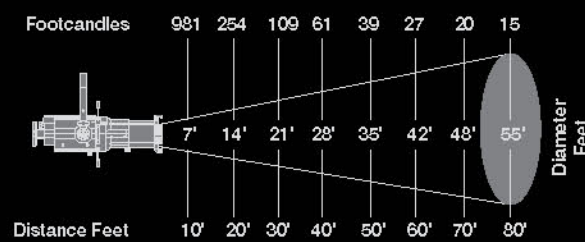

#### S6-30

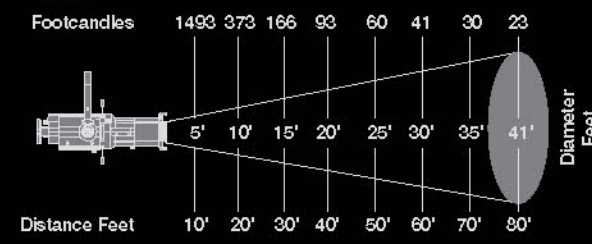

#### S6-50

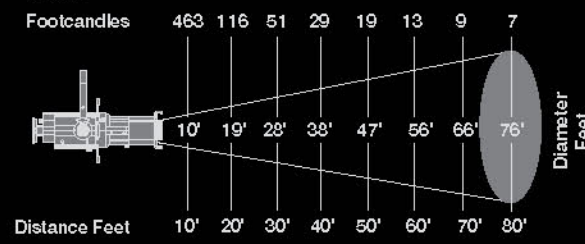

S6-20

### Photometric Data for GLC Lamp

#### S6-1535Z

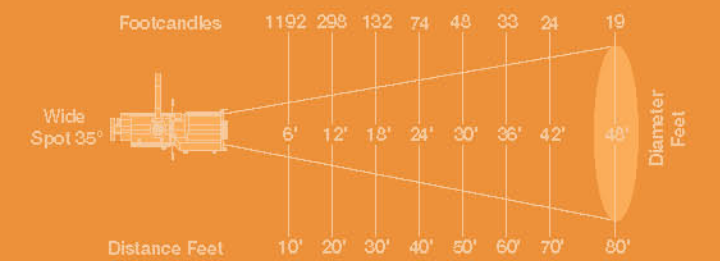

#### S6-3055Z

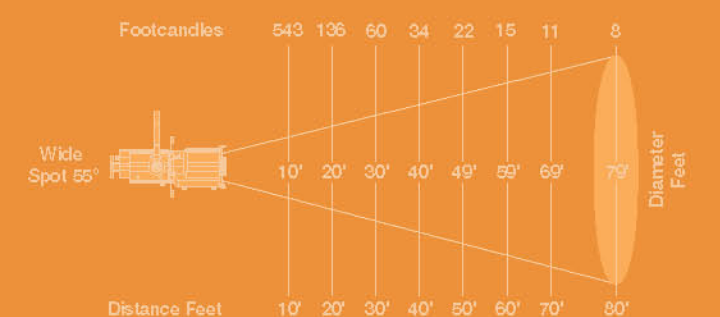
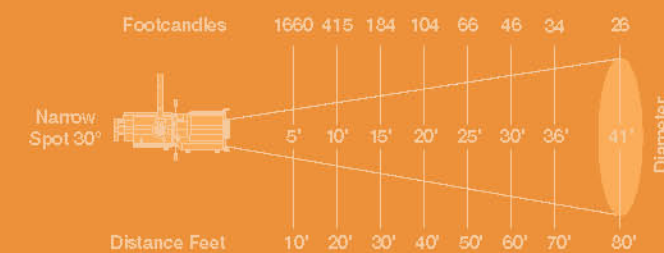

# 750 Watt Die Cast Star Par™ Spotlight/Floodlight

Catalog #: SP-A

The die-cast Star Par is a rugged, lightweight alternative to conventional Par 64 luminaires. The highly polished specular reflector has been designed to operate most efficiently with the new generation of 575 and 750 watt tungsten halogen lamps. The fully rotational lens holder easily accepts a variety of lenses, and the lenses are interchangeable without the use of tools. The removable, two slot accessory holders has a self-closing, self-locking retaining latch for safety. The aesthetic appearance and ergonomically designed function controls add to the appeal of this versatile luminaire.

Max Wattage ..... 750 watts  
 Voltage ..... 120/240 Volts AC/DC, 4.8/2.4 amps  
 Dimensions (in) ..... 11.5W x 13.625H x 11.5D  
 Dimensions (cm) ..... 29W x 35H x 29D  
 Weight ..... 8 lbs. (3.6 kg)



# Par lighting



# 300 Watt PAR38 Spotlight/Floodlight

Catalog #: PAR38

The PAR38 fixture is a low cost, versatile luminaire designed for diverse applications. Intensities and beam spreads are a function of the lamp selected for use in the fixture. One luminaire can serve multiple purposes simply by changing the lamp type. The small size of the PAR38 and a wide range of lamps to choose from make it an ideal luminaire for many lighting applications. Typical installations are found in nightclubs, concerts, theatres and architectural situations where maximum flexibility is desired from a small compact package.

Max Wattage ..... 300 watts  
 Voltage ..... 120/240 Volts AC/DC, 2.5/1.3 amps  
 Dimensions (in) ..... 8.25W x 12.5H x 1.0D  
 Dimensions (cm) ..... 21W x 31.8H x 25.4D  
 Weight ..... 4 lbs. (1.8 kg)



### With 18-0110 VN5P Lens

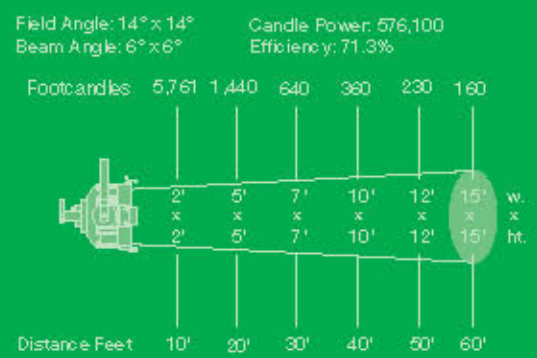

### With 18-0112 MFL Lens

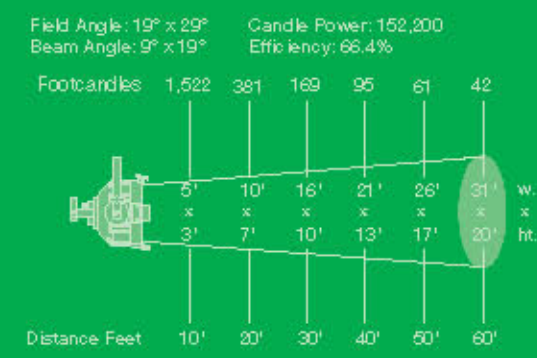

### With 18-0110 VWFL Lens

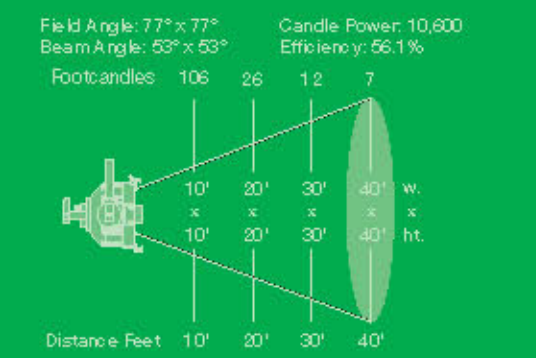

### With 18-0111 NSP Lens

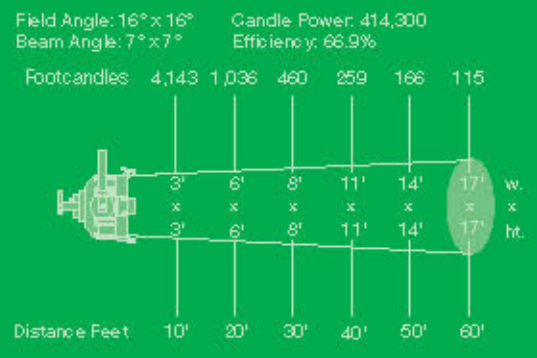

### With 18-0111 WFL Lens

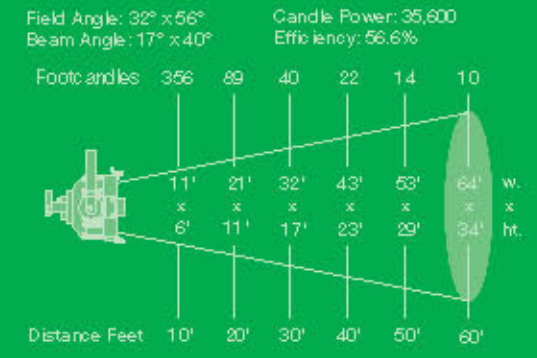

### 250W KR38/SP Lamp

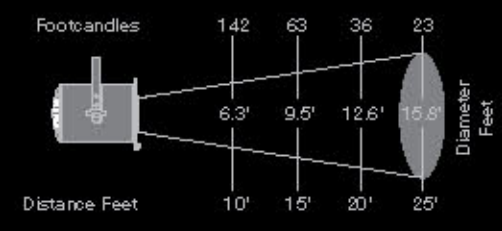

### 250W KR38/FL Lamp

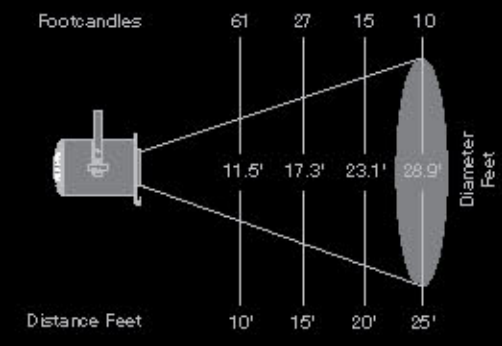

# Par lighting

## 200 Watt PAR46 Spotlight/Floodlight Catalog #: PAR46

The PAR46 Hood is a low cost, versatile luminaire designed for diverse applications. Intensities and beam spreads are a function of the lamp selected for use in the fixture. One unit can serve multiple purposes simply by changing the lamp. The smaller size of the PAR46 offers maximum flexibility. With an oval shaped orientational beam and a 200w lamp, the PAR46 Hood is ideal for use in concerts, nightclubs, television and film remotes and architectural applications where maximum flexibility is desired in a small, compact package.

Max Wattage ..... 200 watts  
Voltage ..... 120 Volts AC/DC, 1.7 amps  
Dimensions (in) ..... 7.75W x 10.25H x 11.75D  
Dimensions (cm) ..... 20W x 26H x 30D  
Weight ..... 7 lbs. (3.15 kg)



PAR46

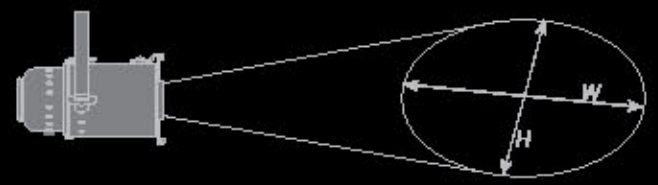

PAR46 Performance Chart

Distance	5'			10'			15'			20'			20'		
	Center Beam F.C. (')	H (')	W (')	Center Beam F.C. (')	H (')	W (')	Center Beam F.C. (')	H (')	W (')	Center Beam F.C. (')	H (')	W (')	Center Beam F.C. (')	H (')	W (')
Lamp															
150PAR46/3MFL	320	2.2	3.5	80	4.4	7.1	36	6.7	10.6	20	8.9	14.2	13	11.1	17.7
200PAR46/3NSP	1,300	1.5	2.0	325	3.0	4.0	144	4.5	6.0	61	6.0	8.0	52	7.5	10.0
200PAR46/3MFL	448	1.8	3.6	112	3.6	7.3	50	5.3	10.9	28	7.0	14.6	18	8.8	18.2
200PAR46/3VWFL	62	6.1	6.4	16	12.2	12.7	7	18.4	19.1	—	—	—	—	—	—

## 300-500 Watt PAR56 and 500-1000 Watt PAR64 and PAR-AL Spot/Flood Light Catalog #: PAR56, PAR64, PAR64-AL

The Par56 and Par64 are low cost, versatile luminaires designed for diverse applications. Intensities and beam spreads are a function of the lamps selected for use in the fixture. One unit can serve multiple purposes simply by changing the lamp. The optional PAR56/64-AR adapter ring allows for the use of PAR56 lamps, offering maximum flexibility. With an oval shaped beam and a lamp range from 300 to 1000 watts, the PAR64 is ideal for use in concerts, nightclubs, television and film remotes and architectural applications where maximum flexibility is desired in a small compact package. The PAR64-AL is identical to the PAR64 with the exception that it is constructed of .050 gauge rolled aircraft aluminum to minimize weight without sacrificing durability.

Max Wattage for PAR56 ..... 500 watts  
Max Wattage for PAR64 ..... 1000 watts  
Voltage for PAR56 ..... 120/240 Volts AC/DC, 4.2/2.1 amps  
Voltage for PAR64 ..... 120/240 Volts AC/DC, 8.3/4.2 amps  
Voltage for PAR64-AL ..... 120/240 Volts AC/DC, 8.3/4.2 amps  
Dimensions for PAR56 (in) ..... 9.125W x 11.125H x 13.75D  
Dimensions for PAR56 (cm) ..... 23.2W x 28.3H x 34.9D  
Dimensions for PAR64 (in) ..... 11W x 15.25H x 16D  
Dimensions for PAR64 (cm) ..... 27.9W x 39H x 40.6D  
Weight for PAR56 ..... 9 lbs. (4.1 kg)  
Weight for PAR64 ..... 11 lbs. (5 kg)  
Weight for PAR64-AL ..... 8 lbs. (3.6 kg)



PAR56/64



Photometric Data For PAR56 and PAR64/PAR-AL

Distance	10'			20'			30'			40'			50'			60'		
	Center Beam F.C. (')	H (')	W (')	Center Beam F.C. (')	H (')	W (')	Center Beam F.C. (')	H (')	W (')	Center Beam F.C. (')	H (')	W (')	Center Beam F.C. (')	H (')	W (')	Center Beam F.C. (')	H (')	W (')
Lamp																		
Q500PAR56/NSP	960	2.6	5.7	240	5.3	11.5	107	7.9	17.2	60	10.5	22.9	38	13.2	28.7	—	—	—
Q500PAR56/MFL	430	3.5	7.7	108	7.1	15.4	48	10.6	23.0	27	14.1	30.7	17	17.6	38.4	—	—	—
Q500PAR56/WFL	190	6.1	13.0	48	12.2	26.0	21	18.3	39.0	12	24.5	52.0	8	30.6	65.0	—	—	—
300PAR56/NSP	700	2.6	3.5	175	5.3	7.1	78	7.9	10.6	44	10.5	14.1	—	—	—	—	—	—
300PAR56/MFL	240	3.5	6.3	60	7.1	12.6	27	10.6	18.9	15	14.1	25.2	—	—	—	—	—	—
300PAR56/WFL	100	5.4	11.5	25	10.7	23.1	11	16.1	34.6	6	21.4	46.2	—	—	—	—	—	—
Q1000PAR64/1	4,000	1.8	4.3	1,000	3.5	8.5	445	5.3	12.8	250	7.0	17.0	160	8.8	21.3	111	10.5	25.5
Q1000PAR64/2	3,300	2.5	4.6	825	4.9	9.2	367	7.4	13.9	206	9.8	18.5	132	12.3	23.1	92	14.8	27.7
Q1000PAR64/5	1,250	3.7	8.0	313	7.4	16.2	139	11.1	24.3	78	14.8	32.3	50	18.5	40.4	35	22.2	48.5
Q1000PAR64/6	400	8.3	14.3	100	16.6	28.5	44	24.9	42.8	25	33.1	57.0	16	41.4	71.3	11	49.7	85.6
Q1000PAR64/NSP	1,800	2.5	5.5	450	4.9	11.1	200	7.4	16.6	113	9.8	22.8	72	12.3	27.7	—	—	—
Q1000PAR64/MFL	800	3.9	8.3	200	7.8	16.6	89	11.7	24.9	50	15.6	33.1	32	19.4	41.4	—	—	—
Q1000PAR64/WFL	330	8.3	14.5	83	16.6	29.1	37	24.9	43.6	21	33.1	58.1	13	41.4	72.7	—	—	—
500PAR64/NSP	1,100	2.3	3.5	275	4.6	7.1	122	6.8	10.6	69	9.1	14.1	44	11.4	17.6	—	—	—
500PAR64/MFL	350	3.5	6.3	88	7.1	12.6	39	10.6	18.9	22	14.1	25.2	14	17.6	31.5	—	—	—
500PAR64/WFL	120	6.3	12.7	30	12.6	25.5	13	18.9	38.2	8	25.2	51.0	5	31.5	63.7	—	—	—

# 1000 Watt 16" Scoop 161

Catalog #: 161

A lightweight multi-purpose ellipsoidal reflector floodlight, the 161 scoop produces a very diffused soft-edged beam of 20 feet in diameter at a distance of 7.5 feet. The 161 is designed to operate high color temperature tungsten halogen lamps. The luminaire is used in theatre and television as both a flood light and a cyclorama fixture. Other uses include photographic and television remote fill light. The scoop is an ideal fixture for color blending and for creating smooth even washes of light.

Max Wattage ..... 1000 watts  
 Voltage ..... 120/240 Volts AC/DC, 8.3/4.2 amps  
 Dimensions (in) ..... 16.5W x 15.125H x 14D  
 Dimensions (cm) ..... 42W x 38H x 36D  
 Weight ..... 8.5 lbs. (3.83 kg)



Photometric Data for 1000W FCM Lamp

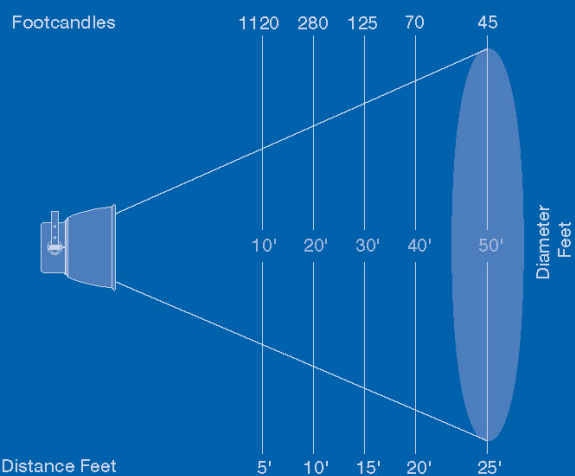

# 1500 Watt 18" Scoop 155

Catalog #: 155

A lightweight multi-purpose elliptical reflector floodlight. The 155 scoop produces a very diffuse, soft-edged beam of 20 feet in diameter at a distance of 7.5 feet. The 155 is designed to operate both standard incandescent and high color temperature tungsten halogen lamps. The luminaire is used in theatre and television as both a flood light and a cyclorama fixture. Other uses include photographic and television remote fill light. The scoop is an ideal fixture for color blending and for creating smooth even washes of light.

Max Wattage ..... 1500 watts  
 Voltage ... 120/240 Volts AC/DC, 8.3/4.2 amps  
 Dimensions (in) ..... 18.5W x 24.5H x 14.5D  
 Dimensions (cm) ..... 47W x 62 H x 37D  
 Weight ..... 8 lbs. (3.6 kg)



Photometric Data for 1500W 1500PS52 Lamp

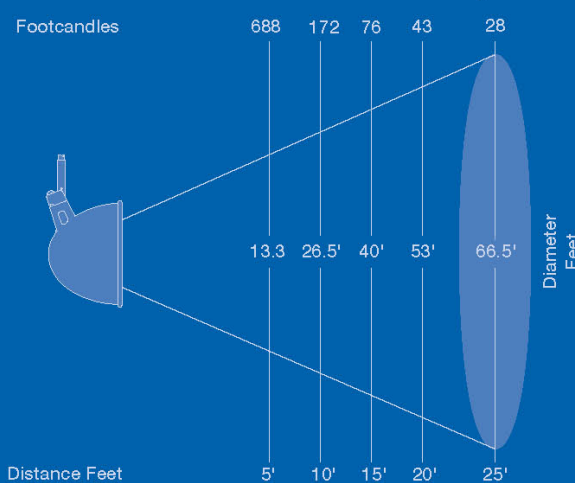

# Scoop lighting



# 400 Watt 10" Scoop/Worklight 153

Catalog #: 153

A lightweight multi-purpose ellipsoidal reflector floodlight, the 153 scoop produces a very diffused soft-edged beam of 12.6 feet in diameter at a distance of 5 feet. The 153 is designed to operate standard incandescent lamps. The luminaire is used in theatre and television as a flood light where space limitation is a factor. Other uses include puppet theatres, museums and show windows. The scoop is an ideal fixture for set hallway and window backings where color blending and smooth even washes of light are required.

Max Wattage ..... 400 watts  
 Voltage ..... 120/240 Volts AC/DC, 3.3/1.7 amps  
 Dimensions (in) ..... 10.75W x 14.125H x 8D  
 Dimensions (cm) ..... 27W x 36H x 20D  
 Weight ..... 5.5 lbs. (2.5 kg)



Photometric Data for 153 with 400G/FL Lamp

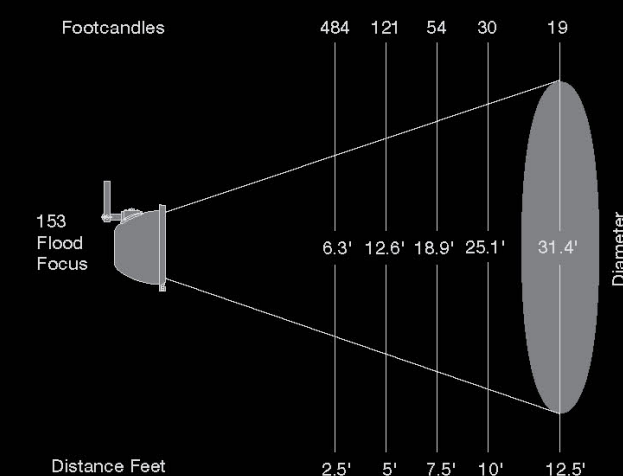

# 1000 Watt 14" Scoop

Catalog #: 154, 160

A lightweight multi-purpose elliptical reflector floodlight, both scoops produce a very diffuse soft-edged beam. The 154 scoop produces a beam diameter of 15 feet at a distance of 7.5 feet, and the 160 scoop produces a beam diameter that varies from 13.5 to 20.7 feet at the same distance. Both luminaires are designed to operate high color temperature tungsten halogen lamp as well as standard incandescent lamps. These fixtures are used in theatre and television as both a flood light and a cyclorama fixture. Other uses include photographic and television remote fill light. The scoop is an ideal fixture for color blending and for creating smooth even washes of light.

Max Wattage ..... 1000 watts  
 Voltage ..... 120/240 Volts AC/DC, 8.3/4.2 amps  
 Dimensions for 154 (in) ..... 16W x 22.75H x 13.5D  
 Dimensions for 154 (cm) ..... 41W x 58H x 34D  
 Dimensions for 160 (in) ..... 16W x 17H x 19.5D  
 Dimensions for 160 (cm) ..... 41W x 43H x 50D  
 Weight for 154 ..... 9 lbs. (4.05 kg)  
 Weight for 160 ..... 8.5 lbs. (3.8 kg)



Photometric Data for 154 with 1000IF Lamp

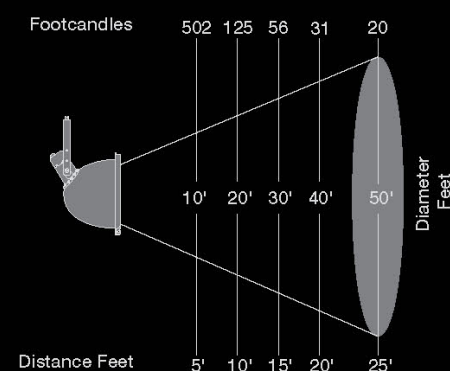

Photometric Data for 160 with EGK Lamp

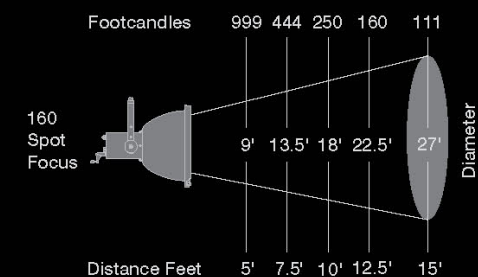

Photometric Data for 160 with EGK Lamp

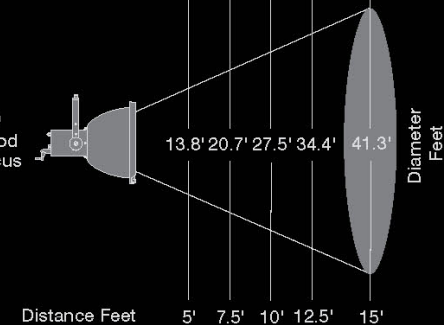

# 360/410-Watt Quartz Halogen Luminator™

Catalog #: Luminator

A ruggedly constructed short to medium throw followspot, the Luminator produces a narrow, hard or soft-edged beam which zooms from 1.3 degrees to 9.3 degrees. With top mounted iris, color boom, and dimmer control handles, this easy to use followspot is designed to utilize the unique high performance FLE, ENX and FXL quartz halogen lamps. The Luminator can be used in any application where manual control of a lighting beam is required to follow a performer and to vary beam size, quality and color.

Max Wattage ..... 360/410 watts  
Voltage ..... 120 Volts AC, Input/4.0 amps max

Dimensions (Not including stand):  
(in) ..... 11.125W x 9.5H x 23.375D  
(cm) ..... 29W x 24H x 59D  
Weight ..... 28 lbs. (12.6 kg) for lamphouse  
28.375 lbs. (12.8 kg) for stand  
Total Net ..... 56.75 lbs. (25.5 kg)



Luminator

### Photometric Data with FLE Lamp

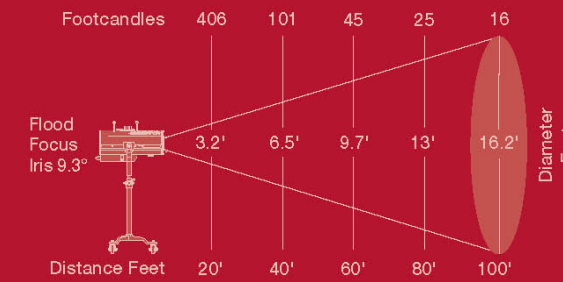
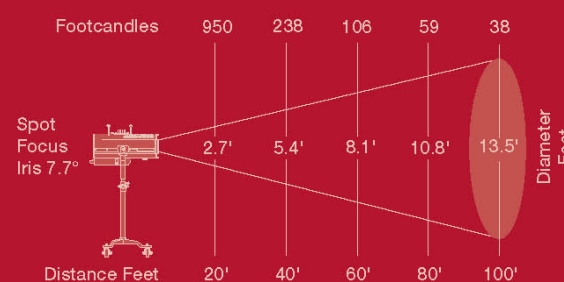
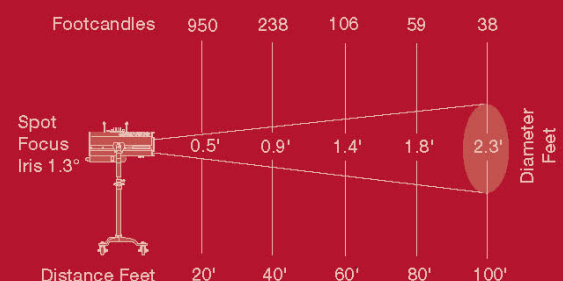

# 360/410 Watt Comet™

Catalog #: Comet

A ruggedly constructed medium to throw long followspot, the Comet produces a narrow, hard or soft-edged beam which zooms from 2.3 degrees to 12.2 degrees. With top mounted iris, shutter, and dimmer control handles, this easy to use followspot is designed to use the unique high performance FLE, ENX and FXL quartz halogen lamps. The Comet can be used in any application where manual control of a lighting beam is required to follow a performer and to vary beam size, quality and color.



Comet

Max Wattage ..... 410 watts  
Voltage ..... 120 Volts AC, 40 amp max.

Dimensions (Not including stand):  
(in) ..... 17.5W x 15.75H x 34.5D  
(cm) ..... 44W x 88H x 88D  
Weight ..... 55 lbs. (24.8 kg) for lamphouse  
36 lbs. (16.2 kg) for stand  
Total Net ..... 91 lbs. (41.2 kg)

### Photometric Data for FLE Lamp

Photometric Data for FLE Lamp

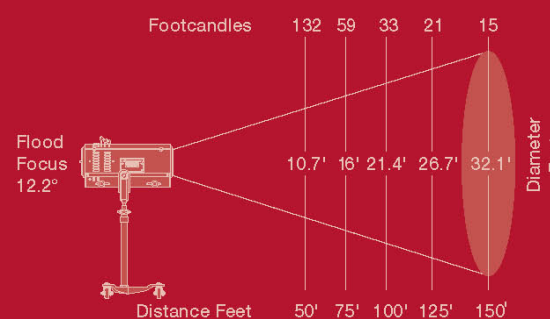
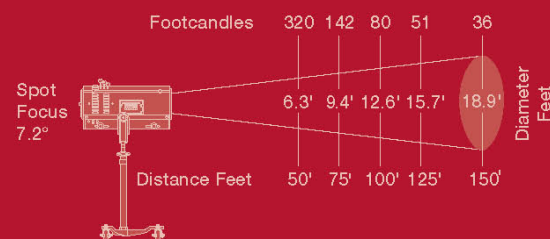
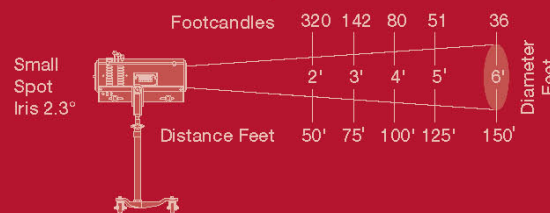

# Followspot

lighting



# 1000Q™ Followspot

Catalog #: 1000Q

A ruggedly constructed medium throw followspot, the 1000Q produces a narrow, hard or soft-edged beam. With easy to use controls mounted at the rear of the luminaire, the beam can be adjusted from spot to flood at any distance. The beam may be further attenuated by using the integral iris for spot size adjustment and the framing shutters for top and bottom edge framing in the flood focus position. The 1000Q is designed for operation only with high performance quartz halogen lamps. The luminaire can be used in any application where manual control of a lighting beam is required to follow a performer and to vary beam size, quality and color.

Max Wattage ..... 1000 watts  
Voltage ..... 120 Volts AC, 9.1 amps

Dimensions (Not including stand):  
(in) ..... 17.5W x 17.5H x 42D  
(cm) ..... 44W x 44H x 107D  
Weight ..... 57 lbs. (25.7 kg) for lamphouse  
36 lbs. (16.2 kg) for stand  
Total Net ..... 93 lbs. (1.9 kg)



1000Q

### Photometric Data for FEL Lamp

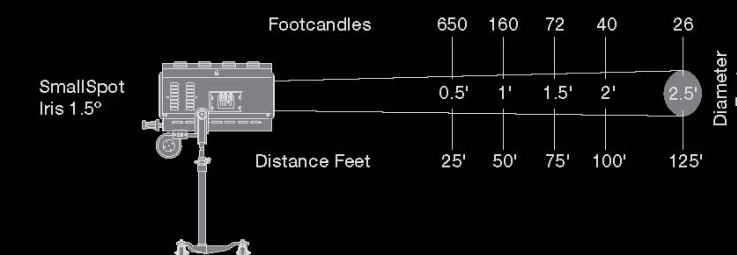
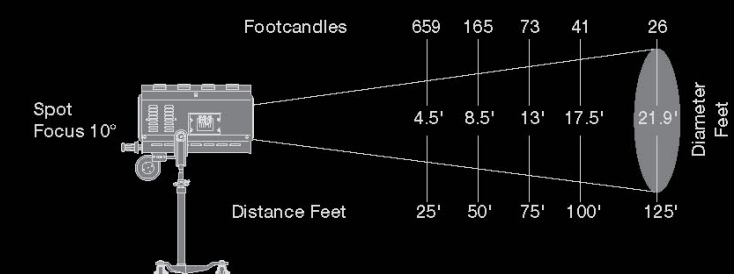
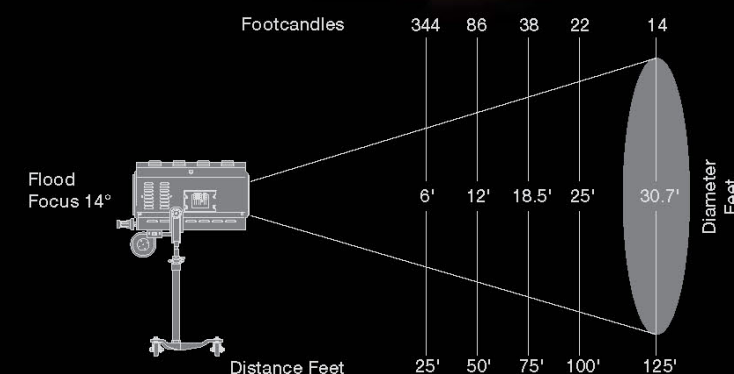



# Followspot

lighting

## 575 Watt Metal Halide Satellite-1 Followspot Catalog #: Satellite-1

A ruggedly constructed medium throw followspot, the SATELLITE-1 produces a hard or soft-edged beam which zooms from a 9.6' to 26.5' diameter circle at a distance of 75' with the iris fully open. The beam may be further attenuated by using the integral iris for spot size adjustment and the integral framing shutters for top and bottom edge framing. The Satellite-1 is designed for use with the 575 watt HMI lamp. The luminaire is used in any application where manual control of a lighting beam is required to follow a performer and to vary beam size, quality and color.

Max Wattage	575 watts	Dimensions (Not Including Stand):	
Voltage	120 Volts AC, 15 amps max	(in)	15.375W x 17.25H x 46D
		(cm)	39W x 44H x 117D
		Weight	69 lbs. (31 kg) for Lamphouse
			52 lbs. (23.4) for Stand
			54 lbs. for ballast & interconnect cable
		Total Net	175 lbs. (78.7 kg)

### Photometric Data for 575 HMI/DE Lamp

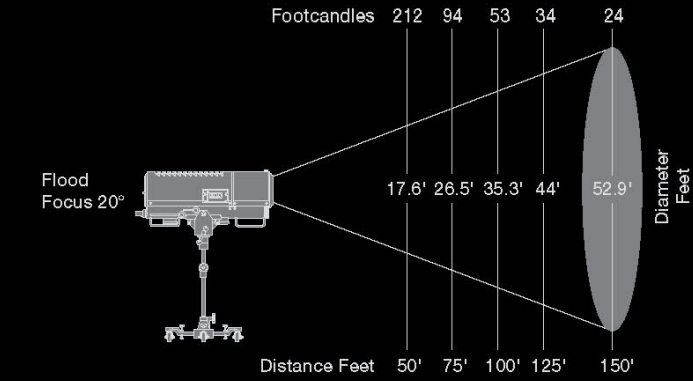
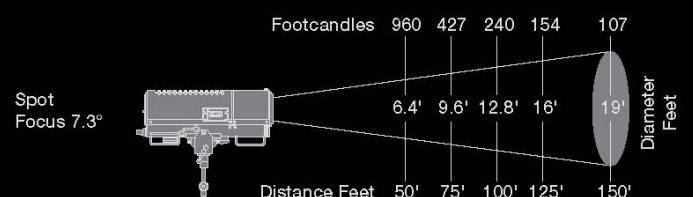
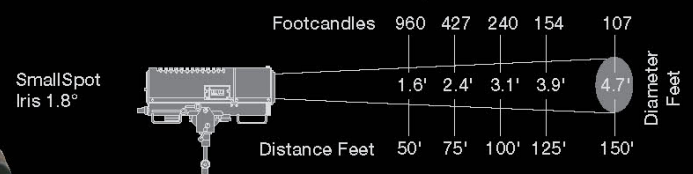

Satellite-1



## 400 Watt HTI Metal Halide Voyager™ Long Throw Followspot Catalog #: Voyager

A ruggedly constructed long throw followspot, the Voyager produces a very narrow hard or soft edge beam which varies from 0.5° to 9.5°. At a distance of 150 feet adjusted to 1° in spot, the beam is 2.6' in diameter and adjusted to 8 in flood, the beam is 21' in diameter. The Voyager is designed for use with the OSRAM 400 watt HTI lamp. The ball bearing slide assembly assures easy operation of the zoom focus feature for spot to flood adjustment. A separate fine focus control assures clean, halation free beam edge. The luminaire is used in any application where manual control of a lighting beam is necessary to follow a performer and to vary beam size, quality and color as required.

Max Wattage	400 watts
Voltage	120 Volts AC, 6.0 amps max
Dimensions (in)	18.5W x 21.625H x 50.25D
Dimensions (cm)	47W x 55H x 128D
Weight	85 lbs. (38.3 kg) for lamphouse
	60 lbs. (27 kg) for stand
Total Net	145 lbs. (65.3 kg)



Voyager

### Photometric Data for HTI 400W Lamp

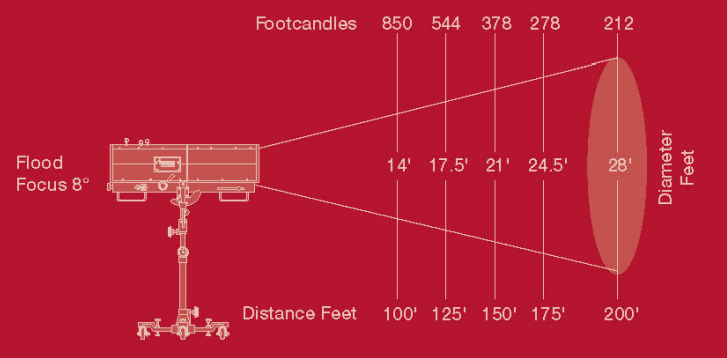
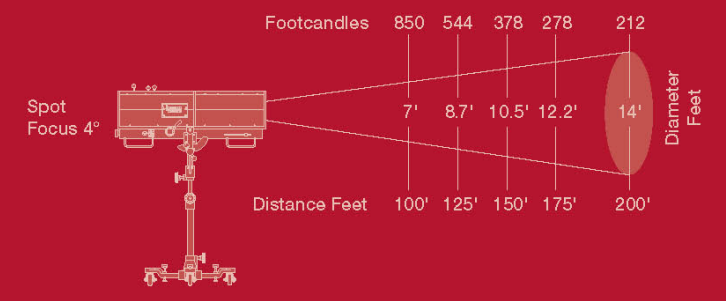
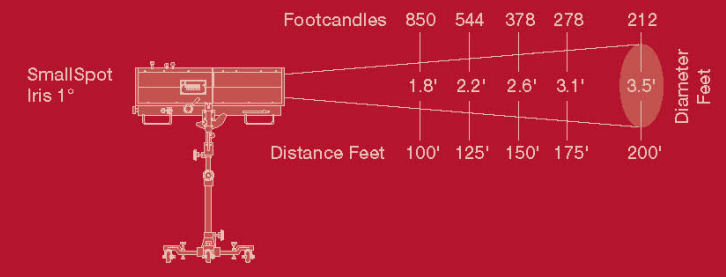

**Z2400 Watts Per Circuit  
520/528 Borderlight  
Catalog #: 520, 528**

The 520 borderlight is a multi-lamp, compartmented striplighting luminaires designed for use as a general wash of light. Available wired for either three or four circuit operation for color separation or blending. The 520 borderlight is manufactured in standard portable lengths of 6 feet, four circuit; 6 feet 9 inch, 3 circuits; 7 feet, 6 inch, four circuit; and 8 feet, three circuits. It is also available in custom lengths and custom circuitry with sockets on 4.5 inch centers. The 520 can be used as toning or fill lights or for cyclorama lighting from both top and bottom.

Max Wattage	.....	2400 watts per circuit
Voltage	.....	120 Volts AC/DC, 20 amps per circuit
Dimensions for 520 (in)	.....	Size made to order
Dimensions for 520 (cm)	.....	Size made to order
Weight for 520	.....	6.5 lbs. (2.9 kg) per foot
Weight for 528	.....	7.5 lbs. (3.4 kg) per foot

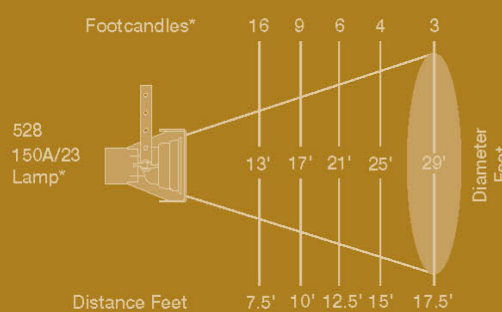
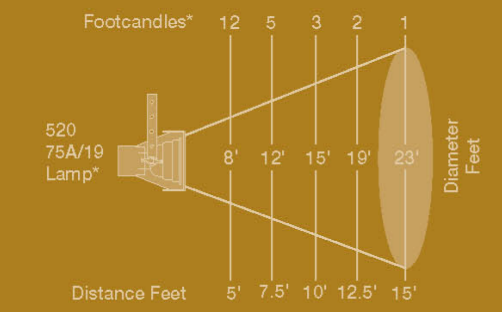

\*All Photometric data is for single lamps only. Actual photometrics dependent on total number of lamps in fixture. Beam intensities compound due to overlapping of beam patterns.

# Borderlights



**300 to 1500 Watt Focusing CYC™  
Ground and SKY Luminaire  
Catalog #: FC-1**

The Focusing Cyc is a lightweight, compact luminaire designed to provide an even wash of light on cycloramas and backdrops, but this lighting instrument can also be used as a multi-purpose flood/fill light for stage and studio lighting applications. The Focusing Cyc has been designed and engineered with a number of innovative details and features that enhance its versatility, efficiency, and performance. Each compartment has a state of the art, highly polished and peened reflector that pivots about the lamp for precision focusing, and a heat resistant knob with indexed position markings is located on the rear of the housing for adjusting and locking the reflector into position. Another feature is the adjustable lampholders which allow the luminaire to accept T-3 to T-8 lamps of three different lengths: 4 11/16" (119mm), 5 5/8" (143mm), and 6 9/16" (167mm). The housing has a pair of rugged tool-free spring-latches which allow multiple units to be safely locked together in a number of ways: a straight row, curved horizontally, curved vertically, or any combination of the three. The convenient, fold-down carry handle also doubles as a loop for a safety cable, and the heat resistant non-skid feet are height adjustable. This eliminates the need for floor trunnions for most ground cyc applications. The super thin safety screen is specially designed to allow maximum light output, and is readily removable for easy access to the lamp for quick, effortless installation and replacement. The optional filter frame holder is hinged and removable without the use of tools. A wide selection of yokes and other hanging hardware are also available to accommodate virtually all Focusing Cyc mounting configurations. An optional accessory for the Focusing Cyc is a unique clips that safely secures stripped glass color frames. With a wide range of non-proprietary lamps of varying wattage, length, and width to choose from, the extremely versatile Focusing Cyc can easily replace a multitude of standard luminaires.

Max Wattage	.....	1500 watts
Voltage	.....	120/240 Volts AC/DC, 12.5/6.3 amps
Dimensions (in)	.....	16W x 11H x 9D
Dimensions (cm)	.....	40.6W x 30H x 23D
Weight	.....	10.5 lbs. (4.73 kg)

**2400 Watts Per Circuit Par 38/R40 Borderlight  
Catalog #: R40**

The R40 borderlight is a multi-lamp, compartmented striplighting luminaire designed for use as a general wash of light. It is available wired for either three or four circuits. The R40 is also available in custom lengths and custom circuitry with sockets on 6 inch centers. The luminaire can be used as a toning or fill light or for cyclorama lighting from both top and bottom.

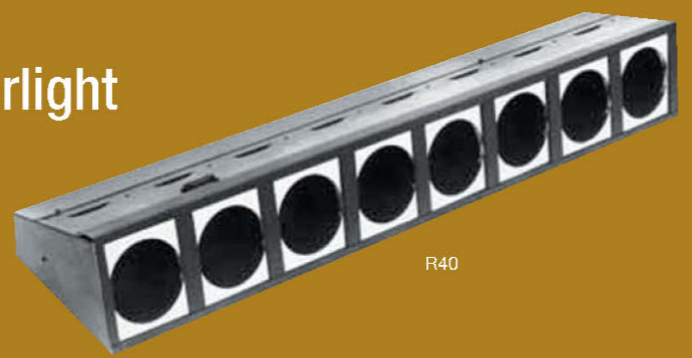

Max Wattage	.....	2400 watts per circuit
Voltage	.....	120 Volts AC/DC, 20 amps per circuit
Dimensions (in)	.....	Size made to order
Dimensions (cm)	.....	Size made to order
Weight	.....	7 lbs. (3.4 kg) per foot

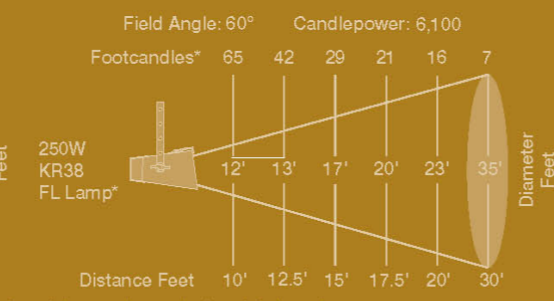
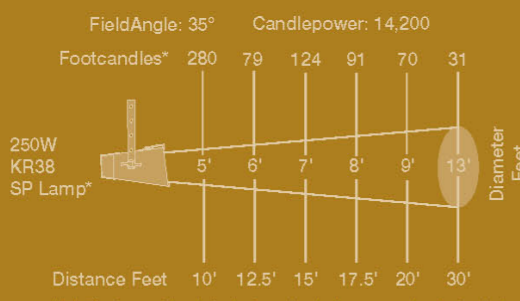

\*All Photometric data is for single lamps only. Actual photometrics are dependent on total number of lamps in fixture. Beam intensities compound due to overlapping of beam patterns.



FC-1

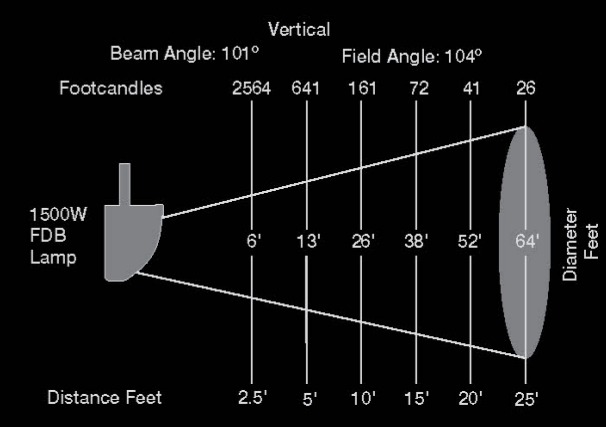
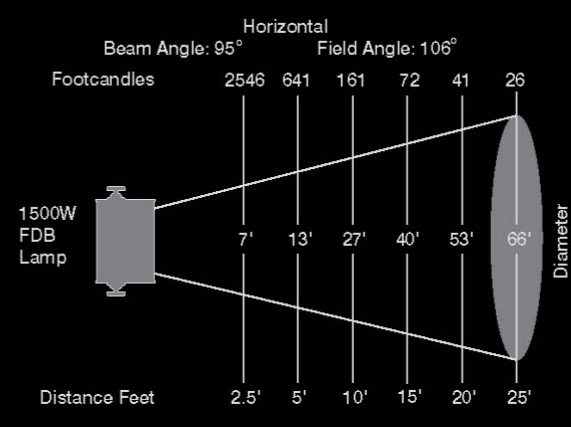

# Borderlights

## 300-2000 Watt EconoCyc™ Ground and Sky Luminaire Catalog #: EC-1

The EconoCyc is a lightweight, compact luminaire designed to provide an even wash of light on cycloramas and backdrops. This lighting instrument can also be used as a multi-purpose flood/fill light for stage and studio lighting applications. The EconoCyc has been designed and engineered with a number of innovative details and features that enhance its versatility, efficiency, and performance. Each compartment has a state of the art, highly polished and peened reflector. Another feature is the adjustable lampholders which allows the luminaire to accept T-3 to T-8 lamps of three different lengths: 4 11/16" (119 mm), 5 5/8" (143 mm), and 6 9/16" (167 mm). The housing has a rugged slide bracket which allows multiple units to be safely locked together, including the Focusing Cyc and others. The optional non skid feet are height adjustable and eliminate the need for floor trunnions for most ground row applications. The super thin safety screen is specially designed to allow maximum light output, and is readily removable for easy access to the lamp for quick, effortless installation and replacement. The filter frame is hinged and removable without the use of tools. A wide selection of yokes and other hanging hardware is also available to accommodate virtually all overhead mounting configurations. An optional accessory for the EconoCyc is a unique clip that safely secures stripped glass color frames. With a wide range of non-proprietary lamps of varying wattage, length, and widths to choose from, the extremely versatile EconoCyc can easily replace a multitude of standard luminaires.

Max Wattage ..... 2000 watts  
Voltage ..... 120/240 Volts AC/DC, 16.7/8.3 amps  
Dimensions (in) ..... 16W x 11H x 8.5D  
Dimensions (cm) ..... 40.6W x 28H x 21.6D  
Weight ..... 9.5lbs. (4.3 kg)

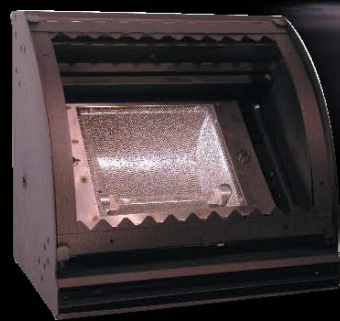

EC-1

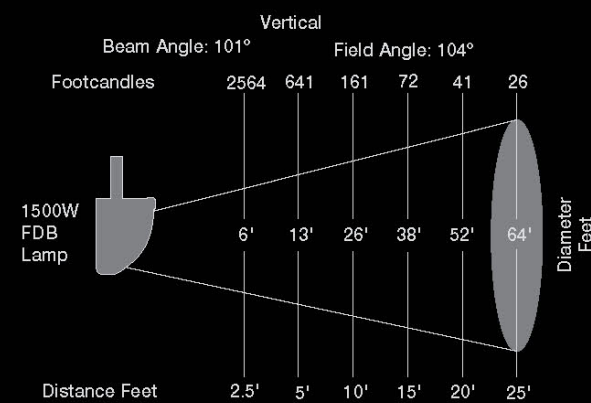
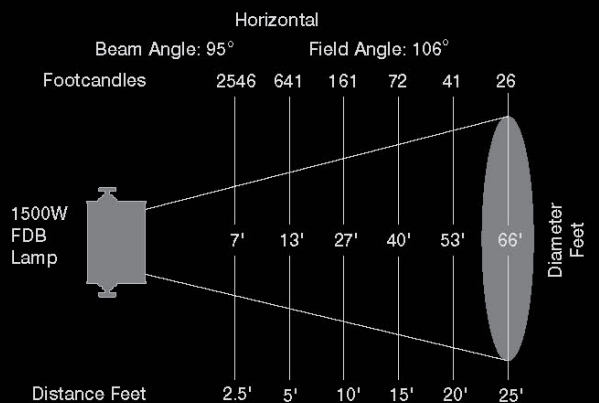

## 1000 Watt Ground Cyc Catalog #: GC-1, GC-2, GC-3, GC-4, GC-5, GC-6, GC-7, GC-8, GC-9, GC-10, GC-11, GC-12

The Ground Cyc is a multi-lamp, compartmented luminaire designed to provide an even wash of light on cycloramas from a ground row position. The luminaire is available in one lamp through twelve lamp configurations with single to twelve circuit wiring. Lamps are on nine inch centers. Typically, each compartment provides an asymmetrical distribution with a 50° beam angle, 70° field angle horizontally and a 65° beam angle, 83° field angle vertically.

Max Wattage ..... 1000 watts  
Voltage ..... 120/240 Volts AC/DC, 8.3/4.2 amps  
Dimensions (in) ..... Size made to order  
Dimensions (cm) ..... Size made to order  
Weight ..... 13.5 lbs (5.9 kg) per foot



GC-1

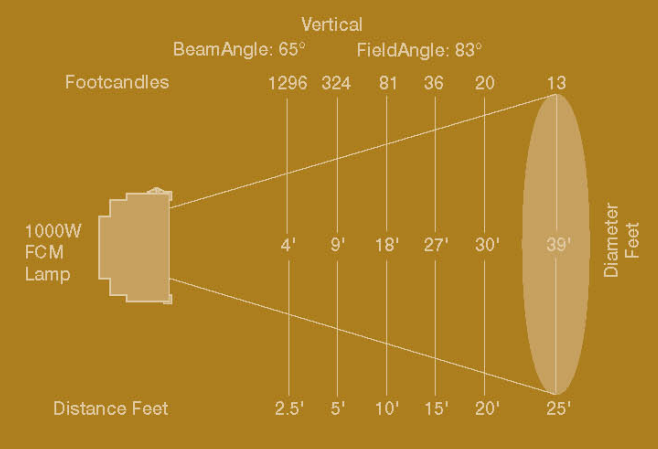
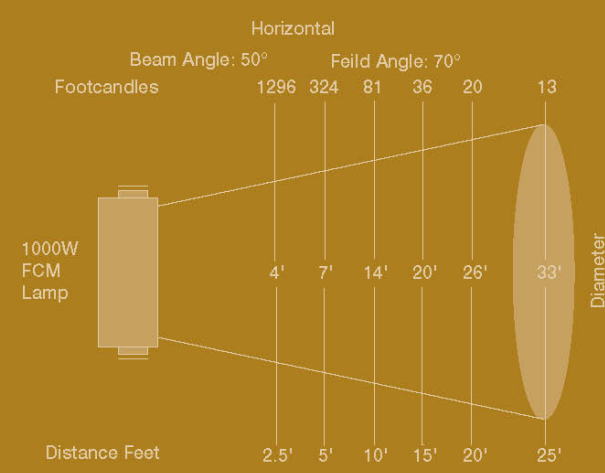

# 1500 Watt Sky-Cyc

Catalog #: SKY-CYC-01,  
SKY-CYC-02H, SKY-CYC-02C,  
SKY-CYC-03, SKY-CYC-04

A lightweight, wide spread, luminaire designed to provide an even wash of light on cycloramas; the four light Sky-Cyc, when mounted 8 feet from the cyc, 12 feet on center will typically provide better than 1.3 to 1 uniformity between luminaires with a minimum of 176 foot-candles at the bottom of a 20' cyc. Available in many configurations, the Sky-Cyc is ideally suited for use in theatres and television studios as a compact, lightweight means of lighting large cycloramas from above.

Max Wattage .....	1500 watts
Voltage .....	120 Volts AC/DC, 12.5/6.25 amps
Dimensions (in) .....	Size made to order
Dimensions (cm) .....	Size made to order
Weight for SKY-CYC-01 .....	12 lbs. (5.4 kg)
Weight for SKY-CYC-02H .....	22 lbs. (9.9 kg)
Weight for SKY-CYC-02C .....	37 lbs. (16.7 kg)
Weight for SKY-CYC-03 .....	28 lbs. (12.6 kg)
Weight for SKY-CYC-04 .....	52 lbs. (23.4 kg)



SKY-CYC

# Borderlights



## 350 Watts Per Circuit MR-11 Micro Strip™

Catalog #: MICS-1, MICS-2, MISC-3

The Altman Micro Strip is a multi-lamp striplight using a wide range of MR-11 tungsten halogen lamps. This luminaire is manufactured of sheet aluminum in three standard lengths. These lengths are related to the number of color washes desired. The popular MR-11 family of dichroic reflector lamps are available in 20 and 35 watts, and in several beam spreads. Since 10 lamps operate in series for each color circuit, lamp failure can be located by neon indicator lamps built into the housing. Spring loaded lamp holders with push-on sockets provide secure positioning of the lamps. This narrow, lightweight fixture allows it to be used in tight spaces where a general wash of light is desired, and is ideal for small clubs, runway lights, and store displays.

Max Wattage .....	350 watts per circuit
Voltage .....	120 Volts AC/DC, 2.9 amps per circuit
Dimensions (in) .....	Size made to order
Dimensions (cm) .....	Size made to order
Weight for MICS-1 .....	6 lbs. (2.7 kg)
Weight for MICS-2 .....	11 lbs. (5 kg)
Weight for MICS-3 .....	17 lbs. (7.7 kg)



MICS-3

SKY-CYC-01, SKY-CYC-02H, SKY-CYC-02V, SKY-CYC-03, SKY-CYC-04

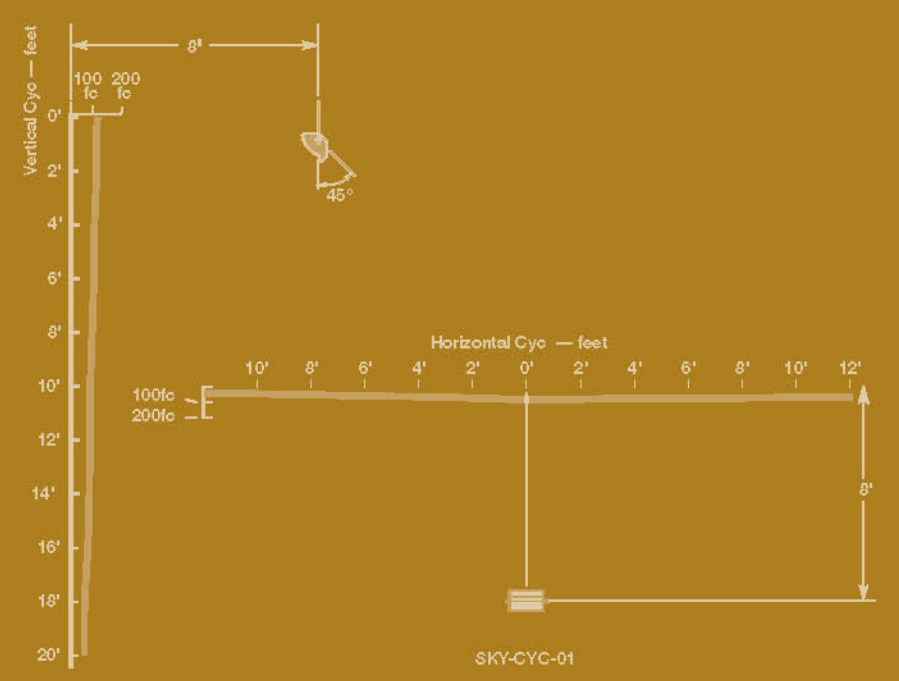
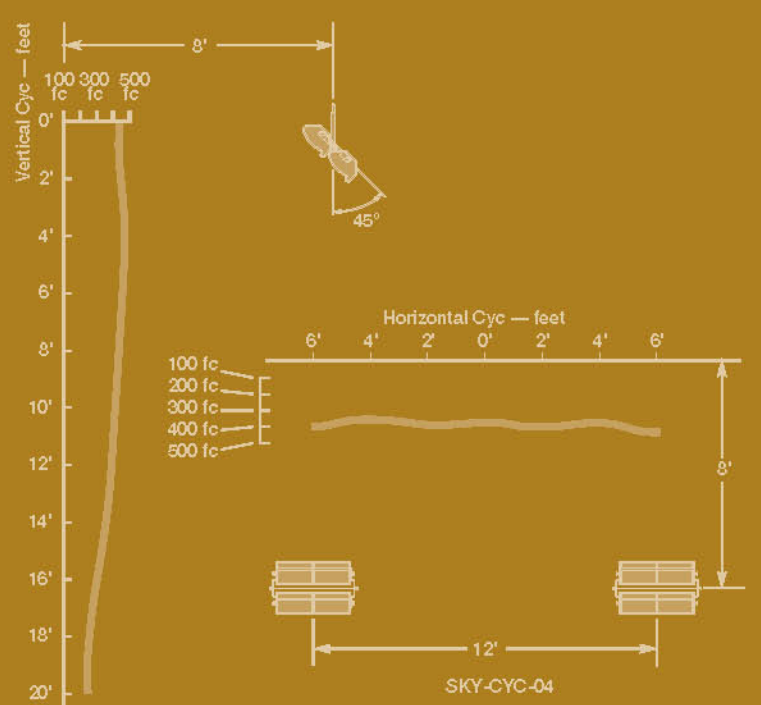

### Photometric Data for FTE Lamp\*

Footcandles	90	40	23	15	10
Distance Feet	10'	15'	20'	25'	30'
Diameter Feet	3'	5'	7'	9'	11'

### Photometric Data for FTH Lamp\*

Footcandles	13	6	3	2	1
Distance Feet	10'	15'	20'	25'	30'
Diameter Feet	8'	12'	17'	21'	25'

### Photometric Data for FTF Lamp\*

Footcandles	30	13	8	5	3
Distance Feet	10'	15'	20'	25'	30'
Diameter Feet	6'	10'	13'	16'	19'

\*All Photometric data is for single lamps only. Actual photometrics dependent on total number of lamps in fixture. Beam intensifies compound due to overlapping of beam patterns.

# Borderlights



## 750 Watts per Circuit MR-16 Zip Strip™ Catalog #: ZS-1, ZS-2, ZS-3, ZS-4

The Zip Strip is a UL listed multi-lamp striplight using a wide range of 12 volt MR-16 tungsten halogen lamps. This luminaire is manufactured of die-cast, extruded and sheet aluminum in four standard lengths. These lengths are related to the number of color washes desired. Narrow spot, medium and wide flood lamps are efficiently incorporated into the Zip Strip without trapping appreciable light from these lamps. Since 10 lamps operate in series for each color circuit, lamp failure is noted by neon indicator lamps. Spring loaded lamp holders with push-on sockets provide secure positioning of the lamps to hold them in place while touring. This narrow luminaire allows it to be used on closely spaced battens or in tight spaces where a general wash of light from the top, side or bottom is desired.

Max Wattage .....	4000 watts
Voltage .....	120/240 Volts AC/DC, 6.3/3.1 amps per circuit
Dimensions (in) .....	Size made to order
Dimensions (cm) .....	Size made to order
Weight for ZS-1 .....	15 lbs. (6.8 kg)
Weight for ZS-2 .....	30 lbs. (13.5 kg)
Weight for ZS-3 .....	45 lbs. (20.3 kg)
Weight for ZS-4 .....	60 lbs. (27 kg)



ZS-3

### Photometric Data for EYF Lamp\*

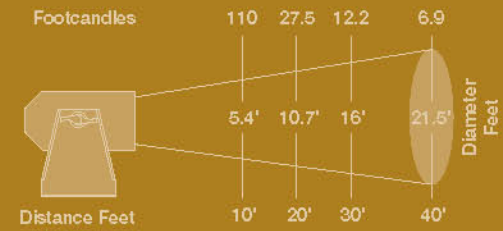

### Photometric Data for EYC Lamp\*

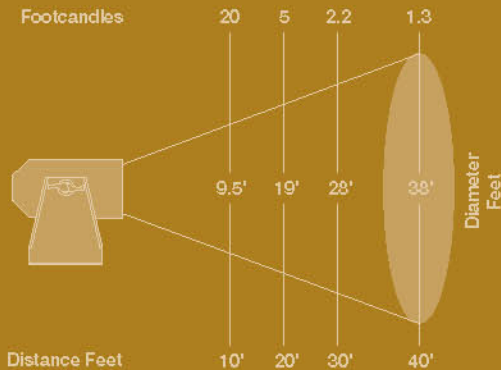

### Photometric Data for EYJ Lamp\*

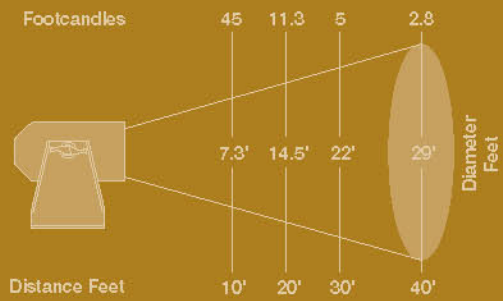

\*All Photometric data is for single lamps only.  
Actual photometrics dependent on total number of lamps in fixture.  
Beam intensifies compound due to overlapping of beam patterns.

**Model: 1000 Watt Soft-Lite-Jr.**  
**Catalog #: Soft-Lite-Jr.**

A compact, lightweight indirect fill-light, the Soft-Lite-Jr. provides a very soft even wash of light. With a virtually shadowless beam, the Soft-Lite-Jr. will uniformly illuminate an area 20.7' x 19.3' at a distance of ten feet with a center intensity of 35 footcandles. The Soft-Lite-Jr. is designed to operate double ended tungsten halogen lamps up to 1000 watts. The luminaire is ideal for confined spaces in the studio or on location where high-performance, indirect, soft fill light is required.

Max Wattage .....	1000 watts
Voltage .....	120/240 Volts AC/DC, 8.3/4.2 amps
Dimensions (in) .....	12.75W x 15.75H x 6.625D
Dimensions (cm) .....	10.8W x 40H x 16.8D
Weight .....	7.5 lbs. (3.4 kg)



Soft-Lite-Jr.

**Photometric Data for Soft-Lite-Jr.**

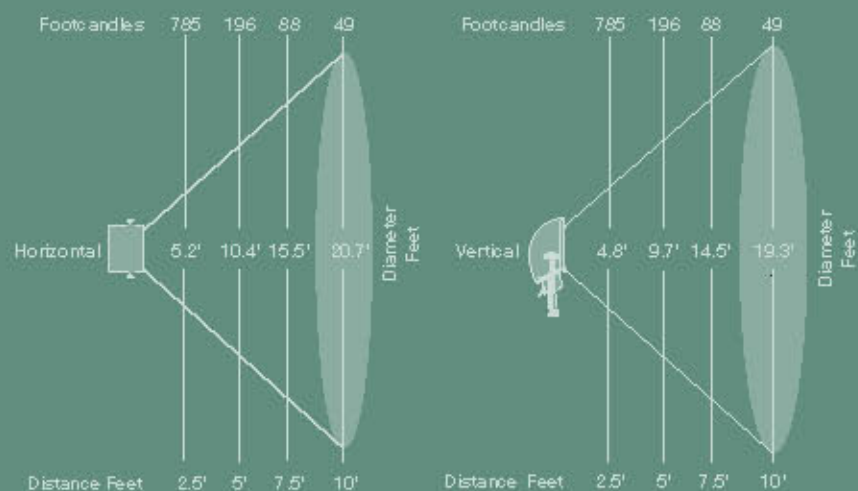

**1000 Watt Soft-Lite**  
**Catalog #: Soft-Lite**

A compact, lightweight indirect fill-light, the Soft-Lite provides a very soft even wash of light. With a virtually shadowless beam, the Soft-Lite will uniformly illuminate an area 26.5' x 23.8' at a distance of ten feet with a center intensity of 96 footcandles. The Soft-Lite comes with dual switching, for intensity control, and is designed to operate double ended tungsten halogen lamps. The luminaire is ideal for confined spaces in the studio or on location where high performance, indirect, soft fill light is required.

Max Wattage .....	1000 watts
Voltage .....	2x120/240 Volts AC/DC, 8.3/4.2 amps
Dimensions (in) .....	23.75W x 15.75H x 6.625D
Dimensions (cm) .....	60.3W x 40H x 16.8D
Weight .....	17 lbs. (17.7 kg)



Soft-Lite

**Photometric Data for Soft-Lite**

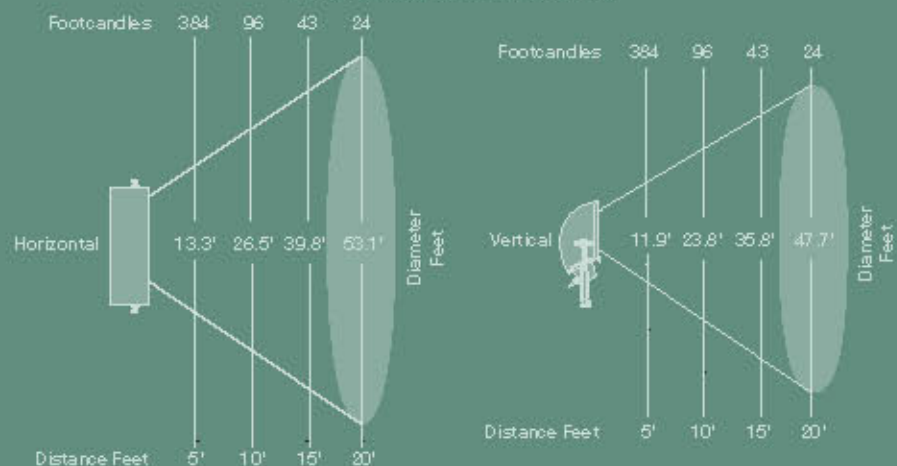

# Film & Video

## lighting



**650/1000 Watt Open-Face Q-Lite™**  
**Catalog #: Q-Lite**

These open-face luminaires are compact, lightweight, multi-purpose flood/fill lights ideal for stage, studio and location lighting applications. They are designed to operate high color temperature tungsten-halogen lamps, and are well suited for use in tight or confined spaces where maximum light output and beam spread are required for fill or flood lighting.

Max Wattage .....	1000 watts
Voltage .....	120/240 Volts AC/DC, 8.3/4.2 amps
Dimensions (in) .....	11.5W x 6.75H x 6.75D
Dimensions (cm) .....	29W x 17H x 17D
Weight .....	7 lbs. (3.15 kg)



Q-Lite

**Photometric Data with FCM Lamp**

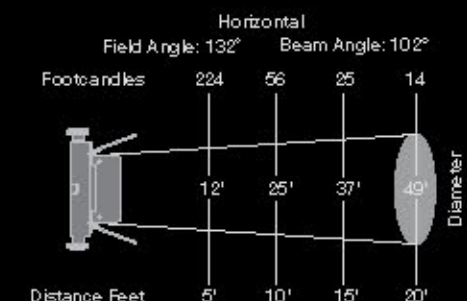
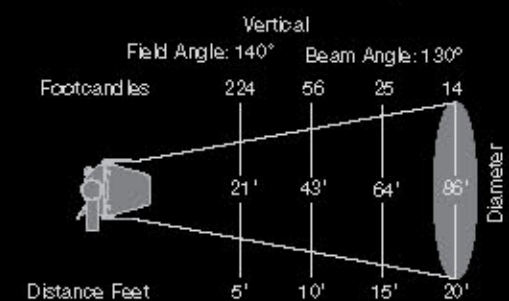

# Film & Video

## lighting

### 300 Watt 300L Catalog #: 300L-HM, 300L-SM

Altman's exciting series of Proline Location and Studio Fresnels offer a brilliant combination of style, durability, performance and efficiency. The 300L is a rugged, compact location set light for use as a small key, backlight or kicker. The luminaire products a powerful 53° beam using a 300-Watt FKW (CP81) lamp. This light features a clam shell door and a short cord for grid mounting or 25' cable with heavy duty in-line switch for location. The Proline 300L has an 80 mm standard focus lens, safety screen, flat steel yoke with combo adapter or pipe clamp, cord wrap and hinged filter frame. This fixture accepts all standard 5" (12.7cm) accessories. Also available for this unit are 4-leaf or 8-leaf barndoors, a 3-in-1 snoot set, and a full compliment of scrims. This fixture is available in either a stand mounted or hanging version. Included in every Proline fixture is Altman's new "F/S EZ Glide System" which allows the tray assembly to flood and spot with ease.

Max Wattage	300 watts
Voltage	120/240 Volts AC/DC
Dimensions (in)	8.5W x 10H x 6.625D
Dimensions (cm)	20.6W x 25.4H x 17.2D
Weight for 300L-HM	6.5 lbs. (2.9 kg)
Weight for 300L-SM	7.4 lbs. (3.4 kg)

Calibrated CCD Camera Measurements with FKW Lamp

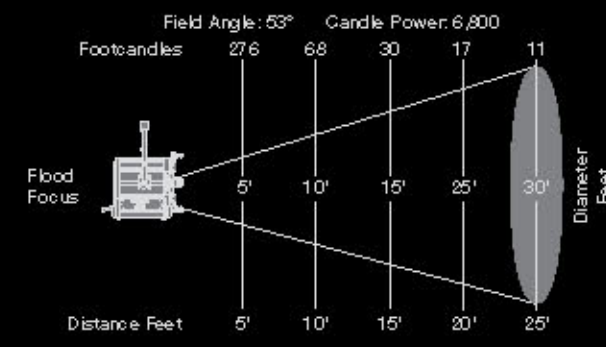
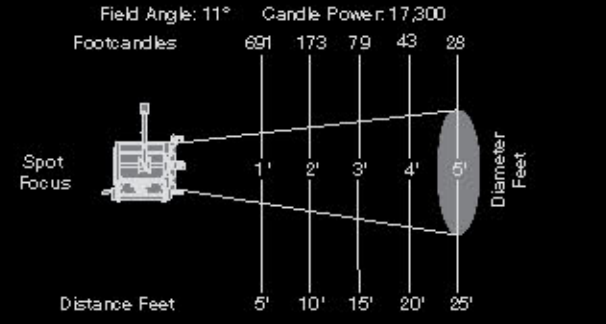

### 650 Watt 650L Catalog #: 650L-HM, 650L-SM

Altman's exciting series of Proline Location and Studio Fresnels offer a brilliant combination of style, durability, performance and efficiency. The 650L serves as a 650W, 500W or 300W small key, backlight or kicker, providing unparalleled lighting across its versatile power range. This features a clam shell door, short cord for grid mounting or 25' cable with a heavy duty in-line switch for location. The Proline 650L has a 112mm standard focus lens, safety screen, flat steel yoke with combo adapter or pipe clamp, cord wrap and hinged filter frame. This light accepts all standard 6 5/8" (16.8 cm) accessories. Also available for this unit are 4-leaf or 8-leaf barndoors, a 3-in-1 snoot set, and a full compliment of scrims. This product comes in either a stand mounted or a hanging version. Included in every Proline fixture is Altman's new "F/S EZ Glide System" which allows the tray assembly to flood and spot with ease.

Max Wattage	650 watts
Voltage	120/240 Volts AC/DC
Dimensions (in)	5.75W x 10.5H x 7.75D
Dimensions (cm)	24.8W x 26.7H x 19.7D
Weight for 650L-HM	7 lbs. (3.2 kg)
Weight for 650L-SM	8 lbs. (3.6 kg)



Calibrated CCD Camera Measurements with FRK Lamp

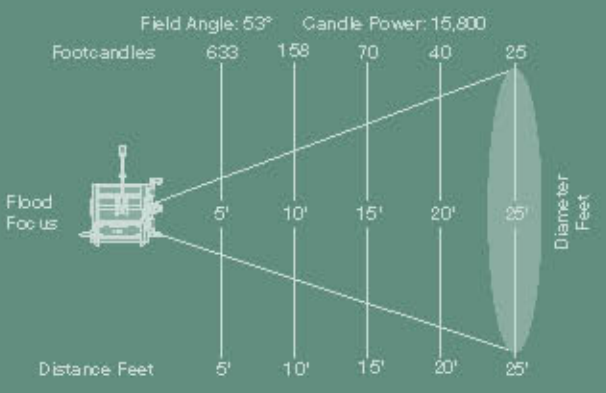
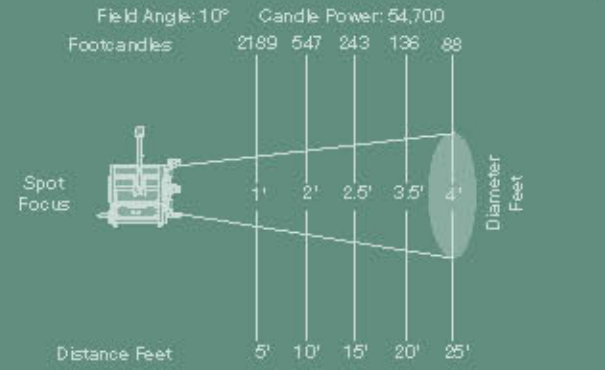

# 1000 Watt 1000L

Catalog #: 1000L-HM, 1000L-SM

The Proline 1000L is designed to handle small key, backlight or kicker applications, yet compact enough to be used on wall plates, hangers and trombones. This light features a front door with spring loaded accessory ear, a short lead for grid use and a 25' cable with heavy duty in-line switch for location. Also supplied with this fixture is a 130 mm short focus lens, safety screen, tubular steel yoke with combo adapter or pipe clamp, cord wrap and hinged filter frame. The 1000L accepts all standard 7 3/4" (19.68 cm) accessories. Also available for this unit are 4-leaf or 8-leaf barndoors, a 3-in-1 snoot set, and a full compliment of scrims. This fixture is available in either stand mounted or hanging versions. Included in every Proline fixture is Altman's new "F/S EZ Glide System" which allows the tray assembly to flood and spot with ease.

Max Wattage	1000 watts
Voltage	120/250 Volts AC/DC
Dimensions (in)	11.25W x 15.25H x 9.75D
Dimensions (cm)	27W x 38.7H x 23D
Weight for 1000L-HM	11.5 lbs. (5.2 kg)
Weight for 1000L-SM	12.5 lbs. (5.7 kg)

### Calibrated CCD Camera Measurements with CYX Lamp

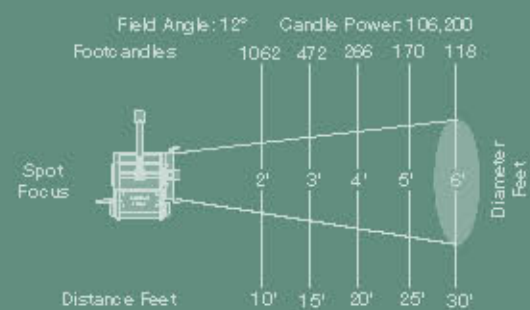
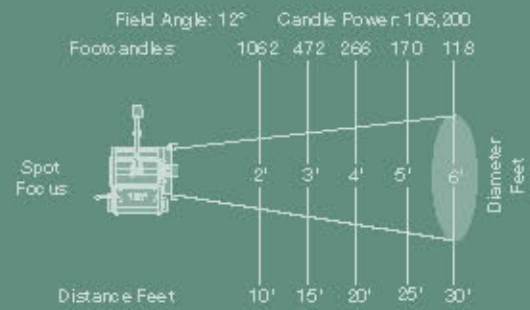

# 2000 Watt 2000L

Catalog #: 2000L-HM, 2000L-SM, 2000L-PO

For use as a keylight, backlight or kicker, the 2000L is indispensable for on-location, in the studio, or for a rental inventory situation. This versatile unit operates with 1000, 1500 or 2000 watt lamps. This Proline fixture features a front door with spring action top accessory ear, a short lead for grid use or a 25' cable with heavy duty in-line switch for location. A 175 mm short focus lens, safety screen, tubular steel yoke with combo adapter or pipe clamp, cord wrap and hinged filter frame are also supplied with this luminaire. The 2000L accepts all standard 9" (22.86 cm) accessories. Also available for this unit are 4-leaf or 8-leaf barndoors, a 3-in-1 snoot set, and a full compliment of scrims. This fixture is available in stand mounted, hanging and pole operated versions. Included in every Proline fixture is Altman's new "F/S EZ Glide System" which allows the tray assembly to flood and spot with ease.

Max Wattage	2000 watts
Voltage	120/240 Volts AC/DC
Dimensions (in)	14.875W x 18.75H x 10.5D
Dimensions (cm)	37.8W x 47.6H x 26.7D
Weight for 2000L-HM	17 lbs. (7.7 kg)
Weight for 2000L-SM	18 lbs. (8.1 kg)
Weight for 2000L-PO	19 lbs. (8.6 kg)

2000L



### Calibrated CCD Camera Measurements with CYX Lamp

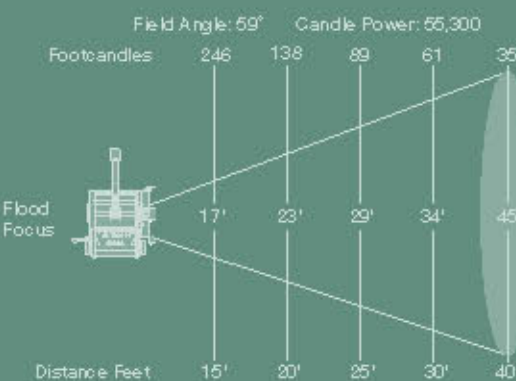
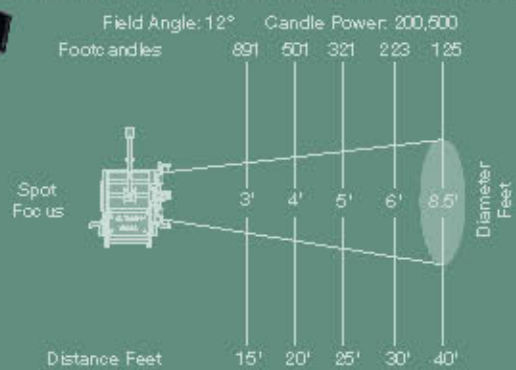

# Film & Video

## lighting

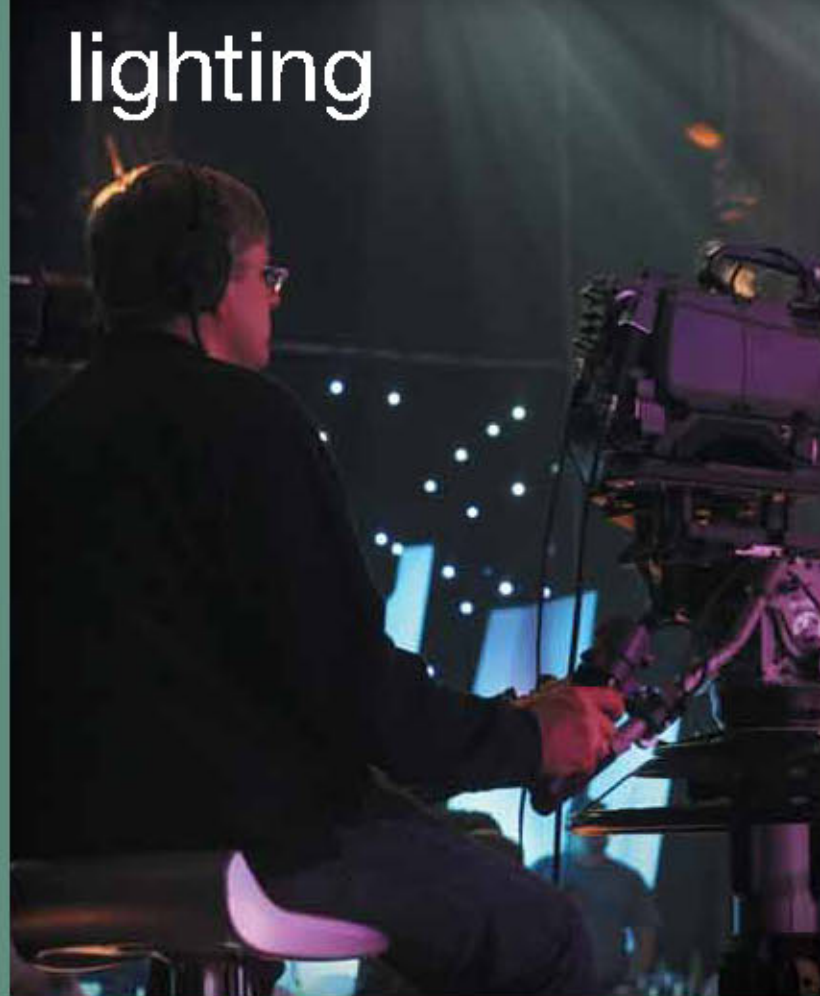

# 1000 Watt 1000S

Catalog #: 1000S-HM, 1000S-SM, 1000S-PO

The 1000S sets a new standard for film, video, broadcast and cable studio use, yet small enough for location work. This light can serve as a keylight, backlight or kicker. It features a front door with spring-action accessory ear, a short lead for grid use or a 25' cable with heavy duty in-line switch for location work. The luminaire also comes with a 175 mm short focus lens, safety screen, tubular steel yoke with combo adapter or pipe clamp, cord wrap and a hinged filter frame. This fixture accepts all standard 9" (22.86 cm) accessories. Also available for this unit are 4-leaf or 8-leaf barndoors, a 3-in-1 snoot set, and a full compliment of scrims. The 1000S is available in stand mounted, hanging and pole operated versions. Included in every Proline fixture is Altman's new "F/S EZ Glide System" which allows the tray assembly to flood and spot with ease.

Max Wattage	1000 watts	Weight for 1000S-HM	16 lbs. (7.2 kg)
Voltage	120/240 Volts AC/DC	Weight for 1000S-SM	17 lbs. (7.7 kg)
Dimensions (in)	14.875W x 17H x 11.5D	Weight for 1000S-PO	22 lbs. (9.9 kg)
Dimensions (cm)	37.8W x 43.2H x 29.2D		



### Calibrated CCD Camera Measurements with EGT Lamp

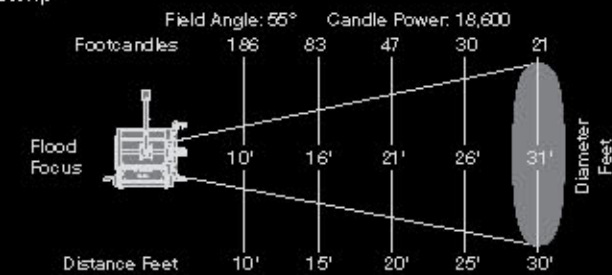
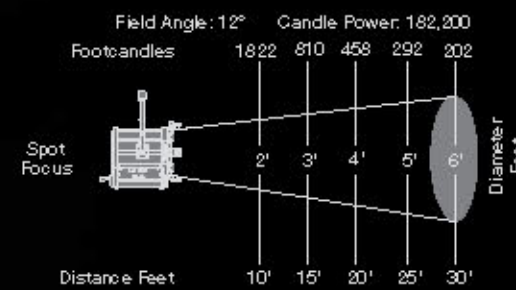

# 2000 Watt 2000S

Catalog #: 2000S-HM, 2000S-SM, 2000S-PO

The Proline 2000S is perfect as a studio spotlight in film, video, broadcast and cable studio applications or on location where a smooth, even field and greater spread is desired. The 2000S series serves as a keylight or backlight. This luminaire features a front door with spring loaded top accessory ear, short lead for grid use or a 25' cable with heavy duty in-line switch for location work. A 250mm short focus lens, safety screen, tubular steel yoke with combo adapter or pipe clamp, cord wrap and hinged filter frame are also included. This unit accepts all standard 13" (33.02 cm) accessories. Also available for this unit are 4-leaf or 8-leaf barndoors, a 3-in-1 snoot set, and a full compliment of scrims. Available in stand mounted, hanging and pole operated versions. Included in every Proline fixture is Altman's new "F/S EZ Glide System" which allows the tray assembly to flood and spot with ease.

Max Wattage	2000 watts	Weight for 2000S-HM	28 lbs. (12.6 kg)
Voltage	120/240 Volts AC/DC	Weight for 2000S-SM	30 lbs. (13.5 kg)
Dimensions (in)	18.675W x 22.75H x 15D	Weight for 2000S-PO	31 lbs. (14.4 kg)
Dimensions (cm)	47.3W x 57.8H x 38.1D		



### Calibrated CCD Camera Measurements with CYX Lamp

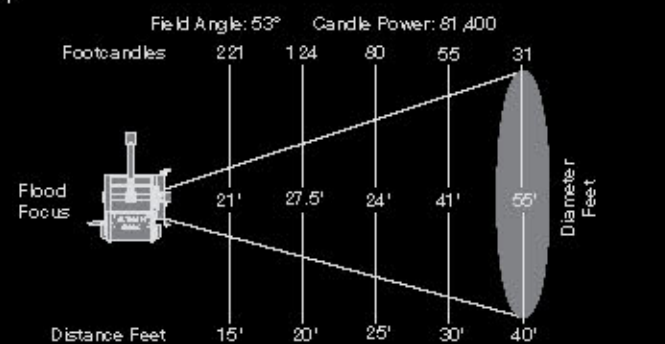
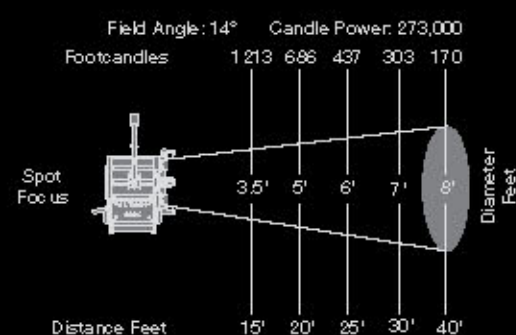



# 150 Watt Outdoor Blacklight Catalog #: UV-150™

The Altman UV-150 is a compact, high output blacklight. It is designed to provide high intensity illumination of fluorescent materials at distances up to 40 feet. The luminaire does not require any fans for cooling, resulting in extremely quiet operation, and it is sealed and designed for wet locations. The ballast is integrated into the housing. The UV-150 is wired with 14/3 HI-Temp rubber cable, and is supplied with a clear safety lens.

Max Wattage ..... 150 watts  
 Voltage ..... 120 Volt, 50/60 Hz  
 15-Watt T6 type lamp and 150-Watt ballast  
 240-Volt AC and 277-Volt AC operation available  
 Dimensions (in) ..... 13.25W x 17.75H x 11.5625D  
 Dimensions (cm) ..... 29W x 37H x 29D  
 Weight ..... 17 lbs. (7.7 kg)



UV-150

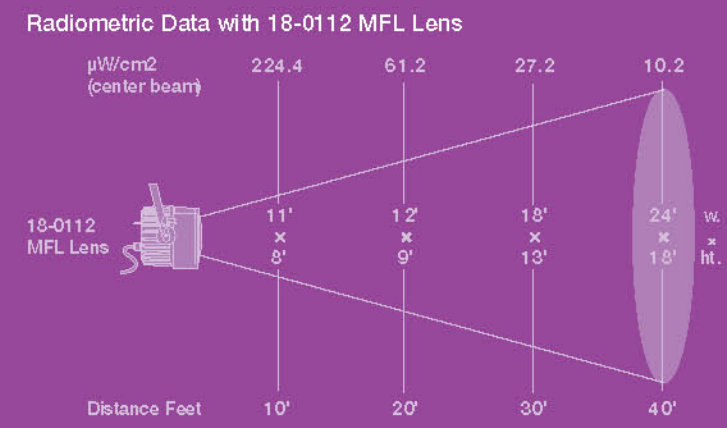

## Additional Accessories for the UV-150

Catalog Number	Item Description	Model	Item Highlights
OD-P64-SN	Combination Snoot/Color Frame Holder with 10"x10" Color Frame	18-0110	Very Narrow Spot Spread Lens (VNSP)
ODC-SN-SHORT	1.5" Short-Nose Combination Frame Holder with 10"x10" Color Frame	18-0111	Narrow Spot Spread Lens (NSP)
8-CF	Additional Color Frame	18-0112	Medium Flood Spread Lens (MFL)
510	Malleable Iron Pipe Clamp	18-0113	Wide Flood Spread Lens (WFL)
510-BLK	Black Malleable Iron Pipe Clamp	18-0114	Very Wide Floor Spread Lens (VWFL)

# Effects

## lighting



# 400 Watt UV-703™ 10" Blacklight Fresnel Catalog #: UV-703

The Altman UV-703 is a compact, high output fresnel blacklight. It is designed to provide high intensity illumination of fluorescent materials at distances up to 150 feet. The fixture does not require any fans for cooling, resulting in extremely quiet operation. The fixture is equipped with barndoor rollers and an integral wire mesh safety screen in front of the lens. The ballast is simple to operate with a single on/off switch with a standard edison connector installed. A special fresnel lens filters out harmful UV-B and UV-C wavelengths and almost all visible light.

Max Wattage ..... 400 watts  
 Voltage ..... 120 VAC single phase, 60 Hz 4.5 amps max  
 Dimensions (in) ..... 20W x 24.5H x 15.5D  
 Dimensions (cm) ..... 51W x 67H x 39D  
 Weight ..... 26 lbs. (11.7 kg)

### Radiometric Data for HPA 400/30-S Lamp

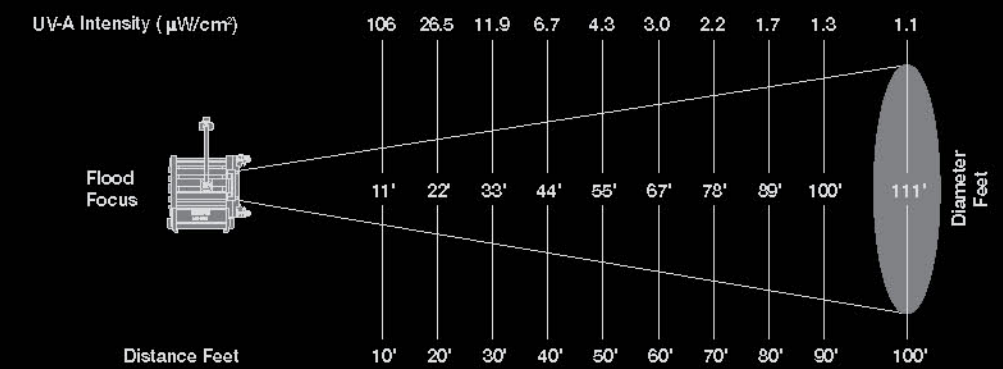
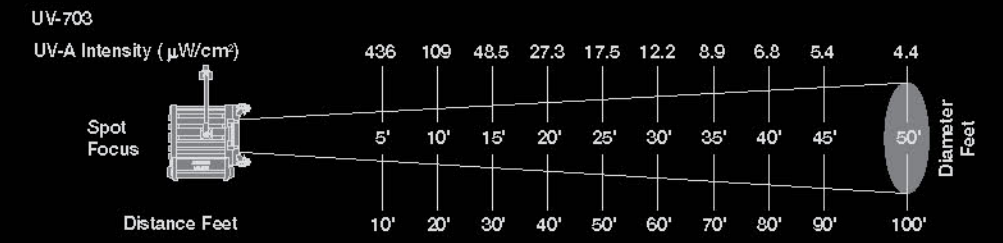

UV-703

# Effects lighting



## 250 Watt UV-250™ Blacklight Floodlight Catalog #: UV-250

The Altman UV-250 is a compact, high output blacklight floodlight. It is designed to provide a wash of high intensity illumination of fluorescent materials at distances of up to 40 feet. The luminaire does not require any fans for cooling, resulting in extremely quiet operation. A special lens filters out harmful UV-B and UV-C wavelengths and almost all visible light, and is provided with an integral wire mesh safety screen.

Max Wattage	..... 250 watts
Voltage	..... 120 Volts 60 Hz A/C operation (208, 240, 277 available)
Dimensions (in)	..... 9.5W x 10.875H x 6.75D
Dimensions (cm)	..... 21.4W x 27.6H x 17.1D
Weight	..... 9 lbs. (8.6 kg)



UV-250

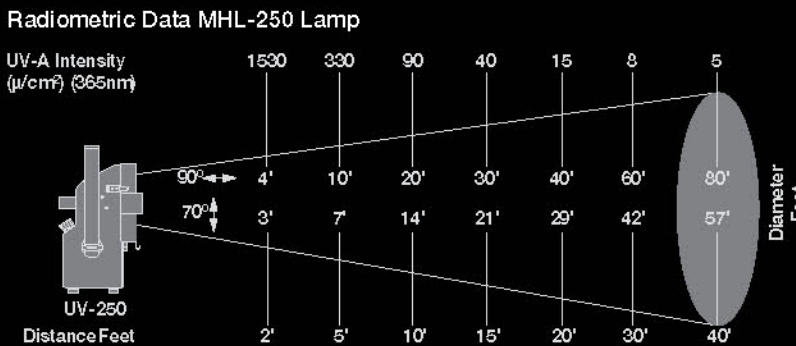

### Radiometric Data for MHL 450 Lamp

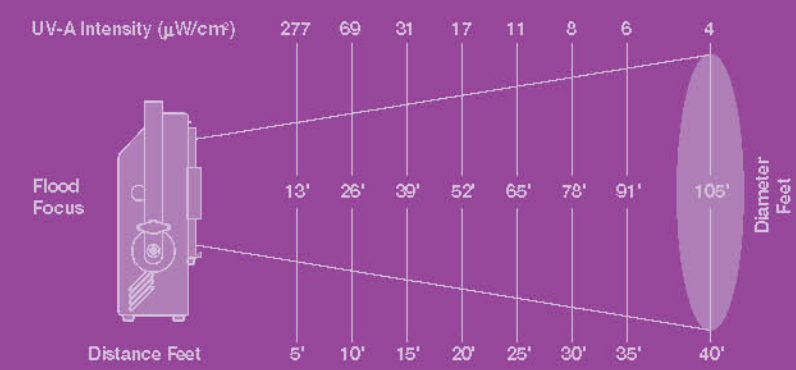
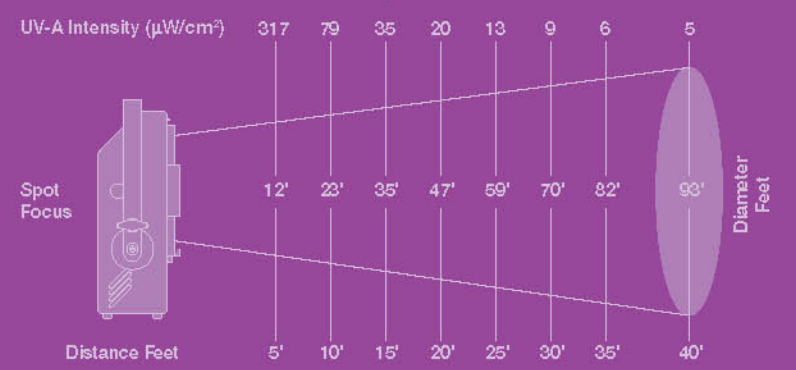

## 400 Watt UV-705™ Blacklight Floodlight Catalog #: UV-705

The Altman UV-705 is a compact, high output blacklight floodlight. It is designed to provide a wash of high intensity illumination of fluorescent materials at distances up to 40 feet. The luminaire does not require any fans for cooling, resulting in extremely quiet operation. The UV-705 comes equipped with an easy-to-use focusing mechanism that allows for adjustments from wide to very wide flood settings. A special lens filters out harmful UV-B and UV-C wavelengths and almost all visible light, and is provided with an integral wire mesh safety screen.

Max Wattage	..... 400 watt
Voltage	..... 120/240 Volts AC/DC, 10/5 amps
Dimensions (in)	..... 10.25W x 17.25H x 5.375D
Dimensions (cm)	..... 26W x 17.25H x 14D
Weight	..... 26 lbs. (11.7 kg)



UV-705

# Distribution

## equipment

### Grounding Pin

52-138GM	20 Amp male, cable mount
52-138GF	20 Amp female, cable mount
52-138GF-FLUSH	20 Amp female, flush panel mount
52-142GM	30 Amp male, cable mount
52-142GF	30 Amp female, cable mount
52-145GM	60 Amp male, cable mount
52-145GF	60 Amp female, cable mount
2FER-GPC	20 Amp females to 1-20 Amp male, 36" Leads
3FER-GPC	20 Amp females to 1-20 Amp male, 36" Leads

### Grounding Straight Blade

52-5266C	15 Amp male edison, cable mount (NEMA 5-15P)
52-5269C	15 Amp female Edison connector, cable mount (NEMA 5)
52-5366C	(2x) 20 Amp male, cable mount (NEMA 5-20P)
52-5369C	(3x) 20 Amp female, cable mount (NEMA 5-20R)
2FER-PBG	(2x) 20 Amp PBG female to 1-20 Amp PBG male, 36" leads

### Grounding Locking Blade

52-4720C	15 Amp male, cable mount (NEMA L5-15P)
52-4729C	15 Amp female, cable mount (NEMA L5-15R)
52-2311	20 Amp male, cable mount (NEMA L5-20P)
52-2313	20 Amp female, cable mount (NEMA L5-20R)
52-9965C	20 Amp male, cable mount (old style)
52-7314C	20 Amp female, cable mount (old style)
52-2310	20 Amp female, flush panel mount (NEMA L5-20R)
52-2315	20 Amp male, recessed panel mount (NEMA L5-20P) for COMET model & VOYAGER Series Follow Spots
52-5215 4 pole/5 wire	20 Amp male, recessed panel mount (NEMA L21-20P) for SATELLITE-1
52-2511 4-pole/5 wire	20 Amp male, cable mount (NEMA L21-20P) for SATELLITE-1 Model interconnect cables
52-2513C 4-pole/5 wire	20 Amp female, cable mount (NEMA L21-20R) for SATELLITE-1 Model interconnect cables
2FER-L5-20	(2x) 20 Amp females to 1-20 Amp male (NEMA L5-20), 36" Leads

## Extruded Aluminum Connector Strip

The connector strip is custom built to your specifications to distribute permanent lighting circuits throughout an installation. Connector supplied to specification can be flush or on pigtails. Connector strips can be mounted either vertically or horizontally, dead hung or from moveable rigging in theatres, television studios and wherever a system of permanent distribution terminating in connections for portable luminaires is desired. Can be used where a more corrosion resistant connector strip may be needed.

## Gridiron Junction Box

The Gridiron Junction Box is a surface mount wiring device usually attached to the grid. It is used to connect the wires within conduit to the multi-conductor flexible cable which feeds striplighting devices or connector strips. These boxes may be located any place where wire connections are required, and are available in many sizes.

GJB-12-24	Gridiron Junction Box, 12 ckt
GJB-16-32	Gridiron Junction Box, 16 ckt
GJB-20-40	Gridiron Junction Box, 20 ckt
GJB-24-48	Gridiron Junction Box, 24 ckt
GJB-30-60	Gridiron Junction Box, 30 ckt
GJB-36-72	Gridiron Junction Box, 36 ckt
GJB-6-12	Gridiron Junction Box, 6 ckt
GJB-8-16	Gridiron Junction Box, 8 ckt

## Flush Floor Box

Flush floor boxes, sometimes called floor pockets, are designed to be permanently mounted in the stage floor, flush with the stage surface. These pockets provide safe temporary connection for theatrical luminaires, minimizing cable crossings. When not in use, the hinged cast aluminum cover remains flush with the stage floor, yet lifts easily to insert or remove the cable connector. Floor boxes are available in a multitude of configurations and designs.

## Flush Wall Box

Flush wall boxes, sometimes called wall pockets, are designed to be permanently mounted in the stage walls, flush with the wall surface. These boxes provide safe temporary connection for theatrical luminaires, minimizing cable crossings. When not in use, the hinged cast aluminum cover remains flush with the stage wall, yet lifts easily to insert or remove the cable connector. Flush wall boxes are available in a multitude of configurations and designs.

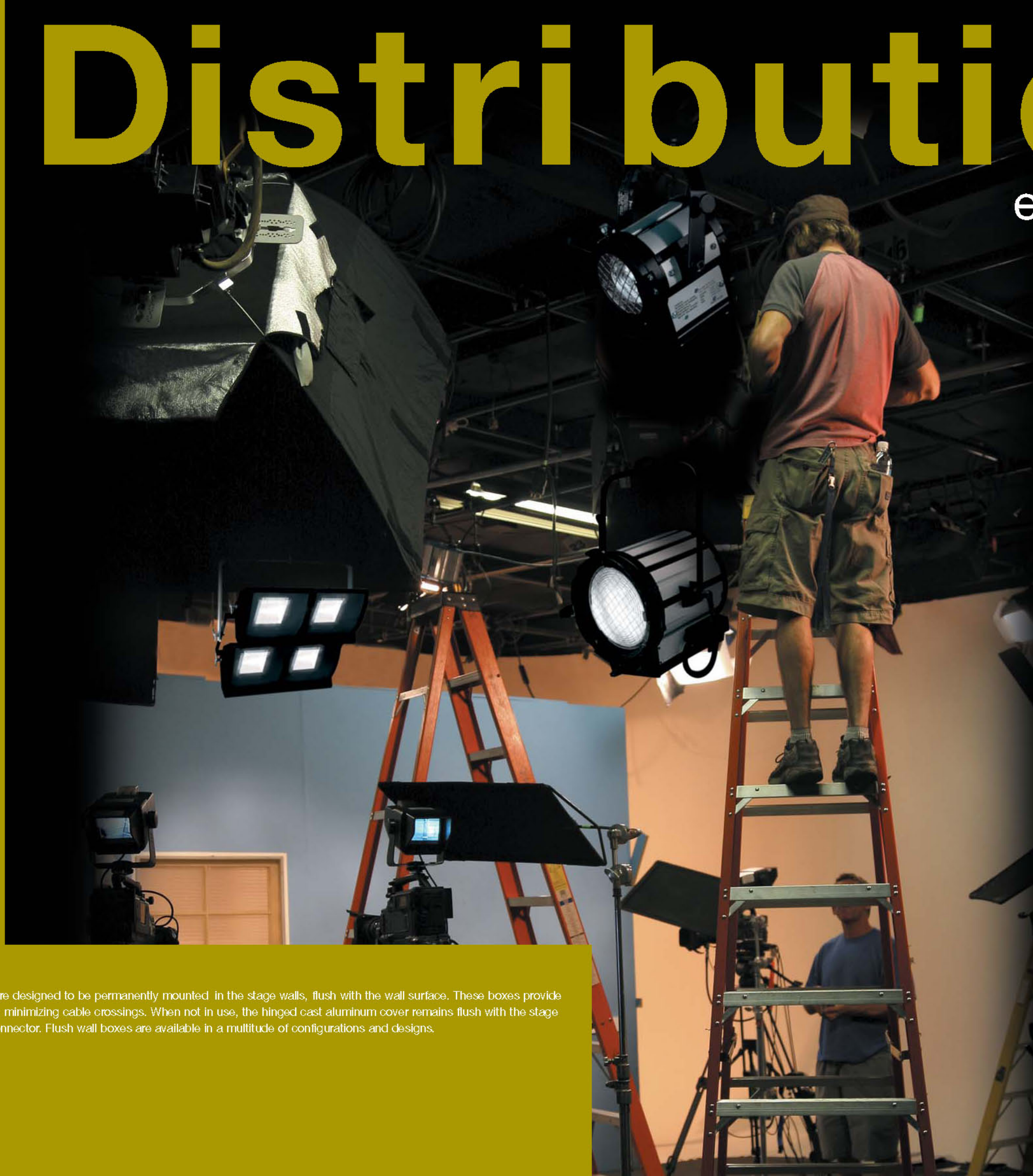

# Accessories



## Color Frames

A metal or plastic frame used to add support to color media on a luminaire. Available for most Altman and other lighting fixtures.



## Snoots

Snoots, or top hats, are devices to reduce light spill. This accessory is available for most Altman lighting fixtures.

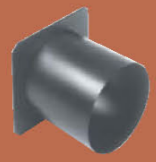

## Pattern Holders

Supports for positioning patterns, or templates, in the optical center of ellipsoidal spotlights. A steel channel pattern holder is available for most ellipsoidal. An aluminum holder with three tabs or sandwich style is also available.



## Drop-In Iris

A plate that contains an iris, (a mechanical means of varying the diameter of a beam of light), which can easily be inserted or removed from an ellipsoidal spotlight.



## Barndoors

An apparatus with adjustable flaps, or "barn doors" that are used to control light spill in a controlled manner. This item is available for most Altman luminaires.



## Color Wheels

A wheel-like device to which 5 colors of gel can be attached. These wheels are rotated by a motor in such a manner that any one specific color gel can be placed in front of a luminaire with relative ease.



## Donuts

A metal plate used to increase the clarity of patterns in an ellipsoidal spotlight by reducing halation and sharpening the image. Available for most Altman ellipsoidal spotlights.

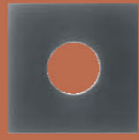

## Scrims

A round, framed metal screen, available in various densities, that acts as a dimmer when placed in front of a luminaire. They are also available so that only half of the frame is screened, allowing for only a portion of the light to be dimmed.



## Roundels

Heat resistant colored glass roundels are used in R40, 520, 528 border, cyc and footlights to provide permanent color washes. Roundels are also stocked as spread beam (50°) for smooth textured lighting effects.



## Side Arms

A side arm is used to extend the mounting positions of luminaires or equipment from a vertical pipe or boom. It comprises a 510 pipe clamp on one end of a length of 1/2" pipe, with one or more sliding tees mounted to the pipe for attaching luminaires or equipment. Baked black enamel finish.



## Pipe Stiffeners

A pipe stiffener is used by attaching the pipe clamp to a batten pipe while tying the loop to the cable supporting the batten. This prevents the batten pipe from rotating within its supports due to torques created by equipment mounted to the batten. Baked black enamel finish.



## Floor Trunnions

Supplied in pairs, floor trunnions are attached to portable borderlights that are to be mounted on the floor. Altman FT and CFT trunnions have two fixture mounting holes to allow for flexibility. Double trunnions allow for mounting two units on one set of trunnions. ZS series trunnions are specially designed for Zip Strips, and MICS series trunnions are specially designed for Mirco Strips. All items are finished in black epoxy sandtex, electrostatic applications.



## Pole Light Lifts

Pole light lifts allow fixtures to be easily raised and lowered from a single attachment point. Comprised of an offset 510 pipe clamp fastened to a 1/2" length of pipe in conjunction with a "stirrup" for attaching a fixture. Baked black enamel finish.

## Extension Clamps

504A extension clamps are for extending the mounting position of luminaries from pipe battens. They are provided with a 510 pipe clamp on one end, and a 1/2"-13 attachment bolt with washers on the other. 506 extension clamps are provided with a 510 pipe clamp on each end for hanging one pipe from another. All items are finished in baked black enamel.



## Specialty Adapters

Adapters are used to convert one type of mounting hardware to another.

# Accessories

## Clamps

Pipe clamps, or "C-clamps" are used for attaching stage luminaires or other equipment to pipe or tubular truss. The 510-2, the 521-A, and the 521-S clamps are designed specifically for securing one pipe to another. The 529 clamp is used to attach large diameter stage cable to a pipe.



## Safety Cables

A steel cable that has a clip on one end and a loop on the other. It is intended to be threaded around a piece of hanging equipment and around a support structure, such as a pipe batten, and then clipped to its loop. It then acts as a safety support should the primary support for the equipment fail.

## Wall Brackets

Wall brackets are designed for attaching fixtures to scenery or other sturdy vertical structures. They are provided with a 1/2"-13 attachment bolt with washers. Textured aluminum finish.



## Cable Cradles

Cable cradles are used to support heavy stage cable from a batten pipe, while simultaneously preventing the cable from entering horizontal sight lines from the house, or audience area, to the stage. Textured aluminum finish.



## Stands, Crossbars and Tee's

Adjustable stands are used to support lighting fixtures or other equipment from the floor. When a crossbar is added to the top of a stand, the combination becomes a light tree which will allow for the mounting of two or more fixtures, depending on the crossbar used. The sliding tees can be set anywhere on the crossbar, and allow for the attachment of the fixtures to the crossbar. All stands mentioned telescope to allow for variable height adjustment. All items are finished in baked black enamel.



Montel Williams Show Studio Set. Lights by Altman™.

## Hanging Irons

Cable cradles are used to support heavy stage cable from a batten pipe, while simultaneously preventing the cable from entering horizontal sight lines from the house, or audience area, to the stage. Textured aluminum finish.



## Bases

Bases are generally used in conjunction with standard iron pipe to create a variety of stands or supports. The B-10 base is generally used without pipe, that is, a fixture is directly mounted to the base. Bases may also be used as weights or counterweights. All items are finished in baked black enamel.



## Light Ladders

Ladders are constructed of steel bar stock channel stringers welded to schedule 40 steel pipe rungs. They are used to hang a group of luminaires from a single heavy duty pipe clamp. Baked black enamel finish.

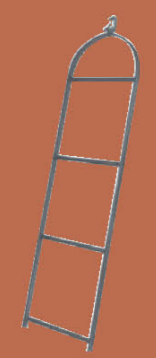

## Stage Hand Wrench

The stagehand wrench accommodates the most commonly used bolt heads and T-handles found on theatrical luminaires and equipment.



## Hanging Arms

Supplied in pairs, hanging arms are used to attach borderlights no longer than 10' in length to batten pipes. Altman hanging arms have five holes spaced 2" apart to allow for flexibility in mounting borderlights. Black epoxy, electrostatic application finish.

## Single Luminaire Ceiling Port

Designed for new construction or renovation work, the RP-1 Recessed Ceiling Port allows for a luminaire to be mounted in a front-of-house position in an unobtrusive, architecturally pleasing manner. Designed for a single fixture, the RP-1 allows access for focusing and relamping from below. Normally located in the ceiling to provide a 45° or flatter angle to the stage, it is also suitable as a balcony front and as a side vertical port.



## Multiple Luminaire Ceiling Port

Designed for new construction or renovation work, the RP-2, RP-3, and RP-4 Ceiling Ports allow luminaries to be mounted in a front-of-house position in an unobtrusive, architecturally pleasing manner. Designed for a 2, 3, or 4 light clusters, the Recessed Ceiling Ports allow access for focusing and relamping from below. Normally located in the ceiling to provide a 45° or flatter angle to the stage, it is also suitable as a balcony front and as a side vertical port.

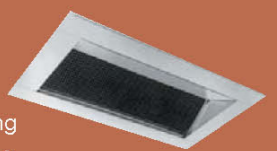

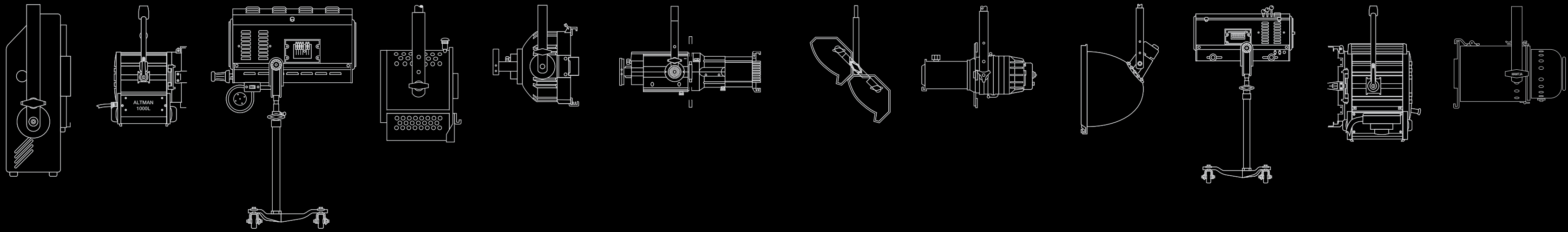

# Thank You...

From the entire Altman family, for your continued business and support. We appreciate your choosing Altman for all of your lighting needs. It's your continued interest in our product line that helps to maintain our reputation as a worldwide leader in the manufacturing of theatrical lighting products. We look forward to serving you.

Thanks again.

Robert Altman

President

Altman Lighting Inc.



Catalog designed by Streamline Graphic Inc. 914.476.7373

Altman Lighting continually engages in research related to product improvement. New materials, production methods, and design refinements are introduced into existing products without notice as a routine expression of that philosophy. For this reason, any current Altman Lighting product may differ in some respect from its published description, but will always equal or exceed the original design specifications unless otherwise stated.

All specifications are subject to change without notice. Altman™, Altman Stage Lighting™, Altman Lighting™, The Quality Of Light®, Bringing Imagination To Light™, MMlirage™, Shakespeare®, Micro Ellipse™, Micro Par™, Micro Strip™, Master Ellipse™, Master Par™, Outdoor Ellipse™, Micro Flood™, Speed Cap™, 360Q™, 1KL™, Spectra Par™, Spectra Cyc™, SpectraSeries™, Smart-Track™, Star Par™, Outdoor Par™, Luminator™, 902™, Dyna Spot™, 1000Q™, Comet™, Satellite™, Orbiter™, Orb-Kit™, Voyager™, Explorer™, Focusing Cyc™, EconoCyc™, Zip Strip™, Q-Lite™, Travel-Lite™, Action Pac™, Model Pac™, Comm Pac™, Foto Pac™, Swing Pac™, Easy Roll™, UV-150™, UV-250™, UV-703™, UV-704™, UV-705™, & Master Spin®, are registered trademarks of Altman Stage Lighting Company, Inc. Some of the products listed in this catalog are protected by applicable patents and patents pending. Altman Lighting will take any legal means necessary to protect and defend its intellectual property.

©2008 Altman Stage Lighting Company, Inc. Altman Lighting, Inc. is a subsidiary of Altman Stage Lighting Company, Inc. All product information and specifications are subject to change.



**Altman Lighting, Inc.**

57 Alexander Street  
Yonkers, NY, 10701 USA

**1-800-4-ALTMAN (1-800-425-8626)**  
914-476-7987 or in NYC 212-569-7777

[altmanlighting.com](http://altmanlighting.com)