

GC-1	GC-4	GC-7	GC-10
GC-2	GC-5	GC-8	GC-11
GC-3	GC-6	GC-9	GC-12

Discontinued January 2019



Fixture Type:

The Ground Cyc is multi-lamp, compartmented luminaire designed to provide an even wash of light on cycloramas from a ground row position. The luminaire is available in one lamp through twelve lamp configurations with single to twelve circuit wiring. Lamps are on nine inch centers. Typically, each compartment provides an asymmetrical distribution with a 50° beam angle, 70° field angle horizontally and a 65° beam angle, 83° field angle vertically.

Specifications subject to change without notice

**1000 WATT
GROUND CYC**

Features

- Die-cast and sheet steel construction
- Asymmetrical distribution for even cyc washes
- Compartmented for color separation
- Porcelain recessed single contacts on 9" centers
- Spring loaded color frame retainers
- Floor trunnions, color frames, and safety cable with spring clip included
- Safety screen(s) included
- U.L. and c.U.L. listed for 1000 watt lamps
- Made in the USA

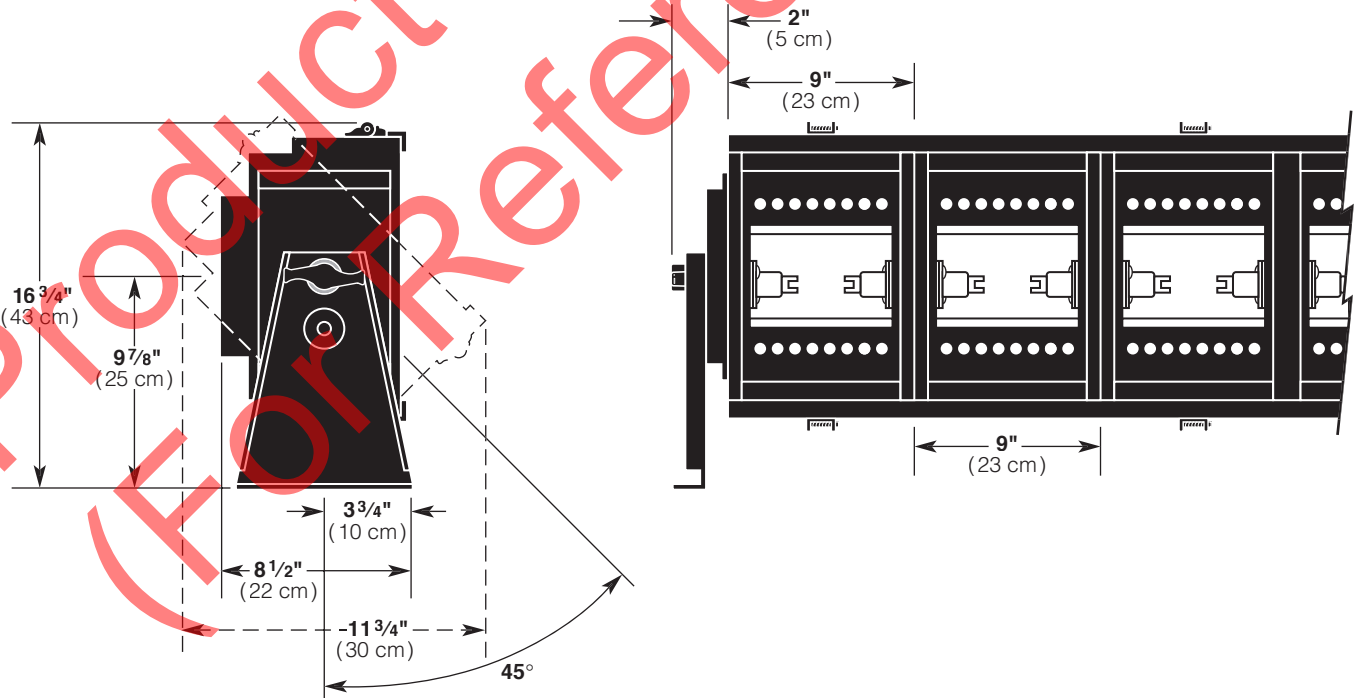

1000 WATT GROUND CYC

Catalog Numbers

GC-1	GC-4	GC-7	GC-10
GC-2	GC-5	GC-8	GC-11
GC-3	GC-6	GC-9	GC-12

Specifications

Housing: Die-cast aluminum and 20 gauge sheet steel.

Materials: Construction employs all corrosion-resistant materials and hardware.

Reflectors: Peened specular aluminum.

Socket: Recessed single contact, two provided. Tool free relamping.

Rating: 120/240 volts AC/DC operation, 8.3/4.2 amps, 1000 watts maximum.

Cable: 36" Teflon and/or silicone-fiberglass leads encased in black fiberglass sleeving.

Safety Screens: Stainless steel, one provided with each section.

Trunnions: Rigid 16 gauge steel, two mounting positions.

Hanging Arms: 3/16" strap steel, five mounting positions.

Hanging Chain: 40" 2/0 zinc plated bowtie chain. One length per 5' provided for units over 10' in length.

Finish: Baked black enamel, for GC-5 thru GC-12. Black epoxy sandtex, electrostatic application for GC-1 thru GC-3.

Weight: Approx; 13 1/2 lbs. (5.9 kg.) per foot.

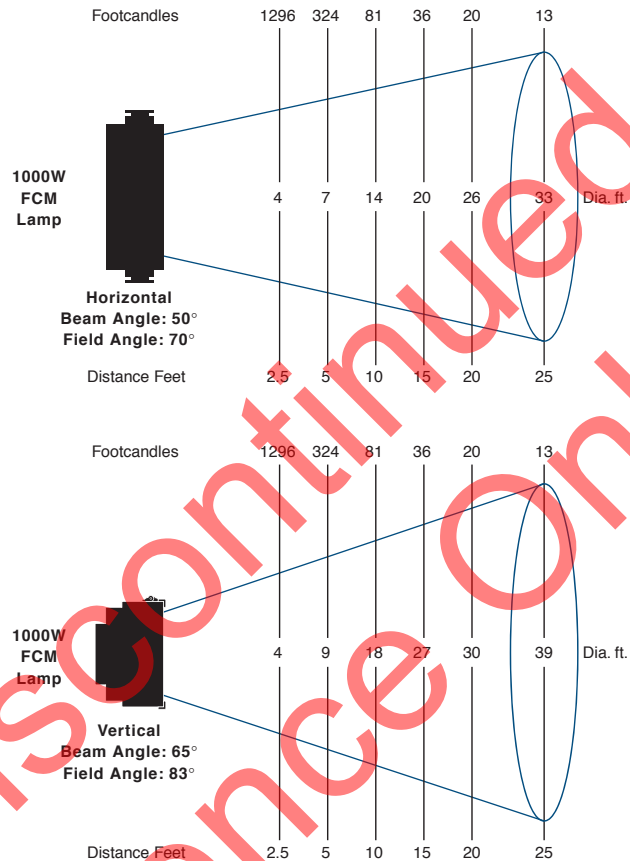

ACCESSORIES Supplied with Luminaire	
GC-CF	8 3/4"x13" Color Frame (one per section)
FT	Floor Trunnion, Pair
SC-36-BK	Safety Cable with Spring Clip

ADDITIONAL ACCESSORIES	
CFT	Castered Floor Trunnion, pair
510	Malleable Iron Pipe Clamp
508	Hanging Arm with Pipe Clamp, pair

When ordering **GROUND CYCS**, specify the following:

- 1) The number of circuits (up to two sections max. may be connected to a single circuit).
- 2) The hardware. FT Floor Trunnions are standard equipment.

GC-1 PERFORMANCE CHART WITH FCM LAMP

Fixture Type	Candlepower (Candela)	Beam Angle (Degrees°)		Field Angle (Degrees°)		Efficiency (%)
		H	V	H	V	
Ground Cyc	8100	50°	65°	70°	83°	45

LAMP DATA

Watts	ANSI Code	Finish	Color Temp (°K)	Lumens	Volts	Rated Life (Hours)	Correction Factor
1000	FCM	Clear	3200	27,500	120	300	1.0
1000	FHM	Frost	3200	26,000	120	300	—
750	EJG	Clear	3200	20,000	120	400	.73
750	EMD	Frost	3200	19,500	120	400	—
500	FDG	Clear	3200	13,250	120	400	.48
500	FDN	Frost	3200	12,800	120	400	—
500	FCL	Clear	3000	10,950	120	2000	.40
500	FCZ	Frost	3000	10,700	120	2000	—
300	EHM	Clear	2950	5,950	120	2000	.22
300	EHZ	Frost	2950	5,900	120	2000	.23