

AFS-700 LED FOLLOW SPOT

780 Watt, White LED

The AFS-700 LED follow spot is a lightweight, 780 Watt white LED manual follow spot that is packed with a powerful feature set at an affordable price. This compact luminaire weighs under 40 pounds (17 kg.) and is a purpose built multi-performance LED follow spot. The AFS-700 LED follow spot follows the traditions of Altman Lighting while introducing several new key features to this performance luminaire.

The AFS-700 LED follow spot's compact, extruded aluminum design allows for discrete luminaire placement while offering powerful light output at distances over 200 feet (60 meters). Offering a motorized - DMX or locally controlled - precision zoom system that delivers a 7° to 13° beam spread. In addition to the motorized zoom, the AFS-700 LED follow spot combines automated beam control with the manual movement of a traditional follow spot. Each AFS-700 LED follow spot includes a on-board controller, allowing for simple button press color control and fade pot control of intensity, strobe, color correction (CTO), iris, focus, and zoom. Each of these features can be controlled from either the AFS-700 controller or via DMX. Add the additional front-end accessory holder to house a number of after-market accessories such as an external color boomerang, top hat, or concentric rings for added beam shaping or color functionality.

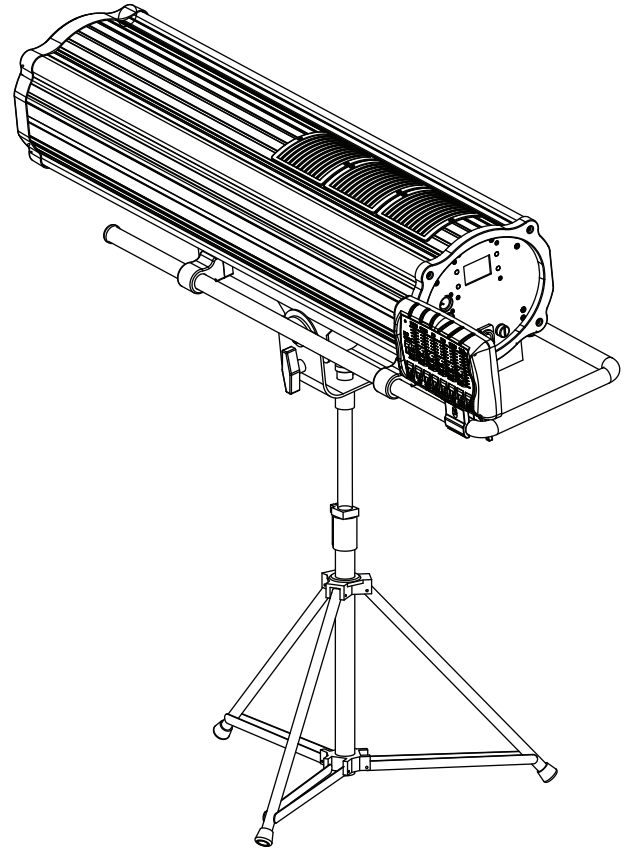

AFS-700 LED Follow Spot & Tripod

Product Features:

- 7600K white LED engine
- 7° to 13° motorized precision zoom system
- DMX or locally controlled:
 - Intensity (dimming)
 - Motorized focus and zoom
 - Touch button color selection
 - Half tone (split) color selection
 - CTO Wheel offering 5600K, 4500K and 3200K
 - Iris
 - Strobe
 - LED on / off
- Discrete feature lock out system
- 100 to 240 VAC 50/60Hz operation with PowerCON input only
- DMX 5-pin input and output/through
- Compatible with DMX 512 protocols (*note, the AFS-700 is not an RDM-enabled luminaire*)
- Local and multi-luminaire operation (*no DMX needed*)
- On-board, simple-to-use user control interface (*control panel detachable*)
- Includes folding tripod stand (polished aluminum finish)
- Luminaire comes in black finish
- Compact, lightweight design Fixture only: 38.3 lbs (17.4 kg) / Tripod only: 12 lbs (5.5 kg)
- Comes with Altman Lighting three year limited warranty
- cETLus listed and CE marked for indoor use

Photometric Performance

**AFS-700 LED FOLLOW SPOT
PHOTOMETRIC SCORE CARD -
7600K (native)**

CCT	7634K
DUV	-0.0091
CRI (Ra)	83
CQS	75
TLCI (Qa)	61.2
TM-30-15 rf	77
TM-30-15 rg	98

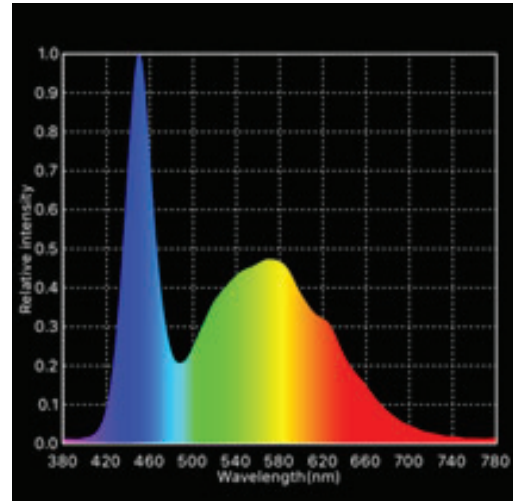
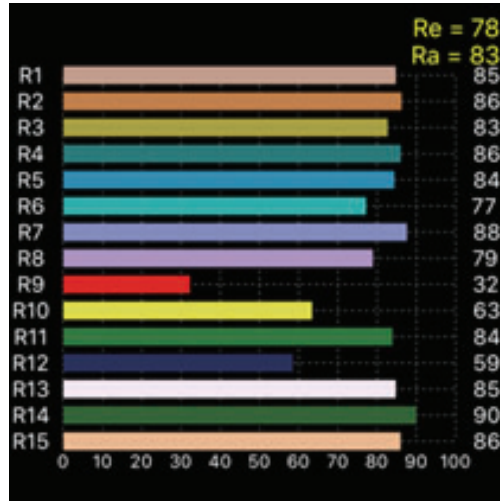

**AFS-700 LED FOLLOW SPOT
PHOTOMETRIC SCORE CARD -
CTO WHEEL POSITION 1**

CCT	5455K
DUV	-0.0102
CRI (Ra)	83
CQS	75
TLCI (Qa)	59.8
TM-30-15 rf	77
TM-30-15 rg	98

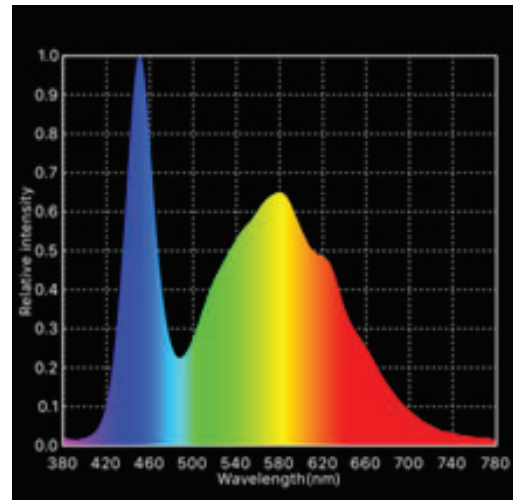
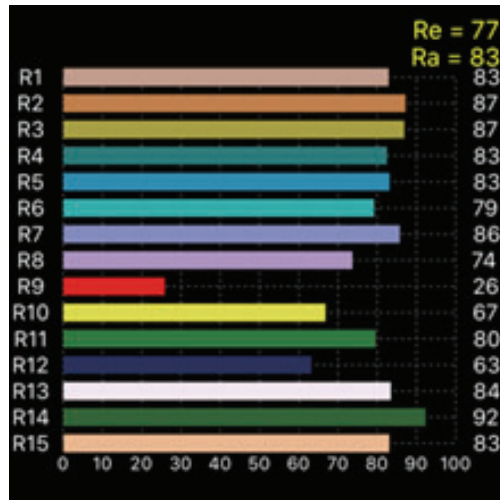

Photometric Performance

**AFS-700 LED FOLLOW SPOT
PHOTOMETRIC SCORE CARD -
CTO WHEEL POSITION 2**

CCT	4657K
DUV	-0.0039
CRI (Ra)	79
CQS	75
TLCI (Qa)	57.2
TM-30-15 rf	77
TM-30-15 rg	95

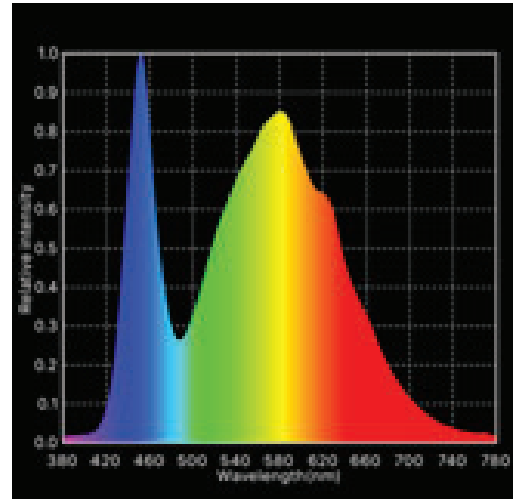
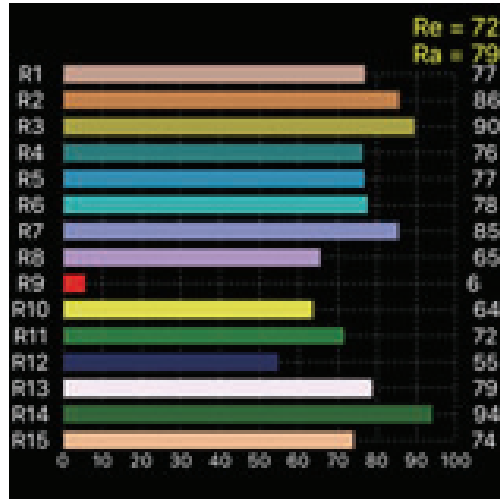

**AFS-700 LED FOLLOW SPOT
PHOTOMETRIC SCORE CARD -
CTO WHEEL POSITION 3**

CCT	3055K
DUV	-0.0120
CRI (Ra)	79
CQS	74
TLCI (Qa)	54.4
TM-30-15 rf	74
TM-30-15 rg	99

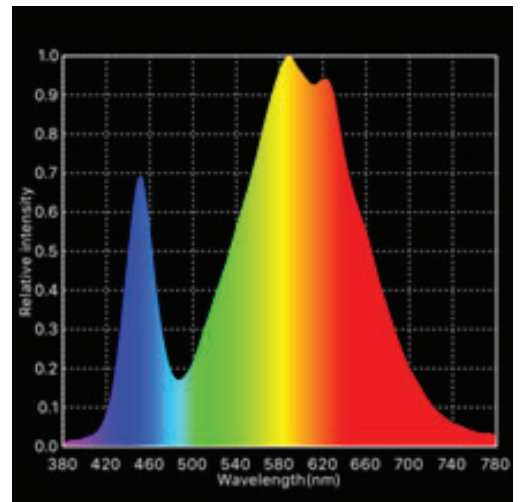
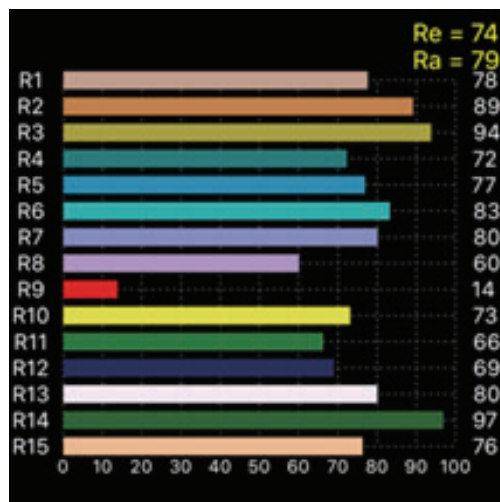

Photometric Performance

AFS-700 LED Follow Spot at 7° (sharp focus)
Delivered beam lumens: 13,925

Throw Distance	50' (15.24m)	75' (22.86m)	100' (30.48m)	125' (38.1m)	150' (45.72m)	175' (53.34m)	200' (60.96m)
Field Diameter (feet)	6.0	9.17	12.23	15.29	18.35	21.41	24.47
Field Diameter (meters)	1.83	2.80	3.73	4.66	5.59	6.53	7.46
Illuminance (FC)	552.0	245.3	138.0	88.3	61.3	45.1	34.5
Illuminance (LUX)	5941.7	2640.7	1485.4	950.7	660.2	485.0	371.4

AFS-700 LED Follow Spot at 13° (sharp focus)
Delivered beam lumens: 10,099

Throw Distance	50' (15.24m)	75' (22.86m)	100' (30.48m)	125' (38.1m)	150' (45.72m)	175' (53.34m)	200' (60.96m)
Field Diameter (feet)	12.2	18.42	24.56	30.7	36.84	42.97	45.57
Field Diameter (meters)	3.71	5.61	7.49	9.36	11.23	13.10	13.89
Illuminance (FC)	122.9	54.6	30.7	19.7	13.7	10.0	7.7
Illuminance (LUX)	1322.9	587.9	330.7	211.7	147.0	108.0	82.7

Note: Photometrics data on this page taken with 7600K native white LED output (no CTO or color).

Product Dimensions (Luminaire)

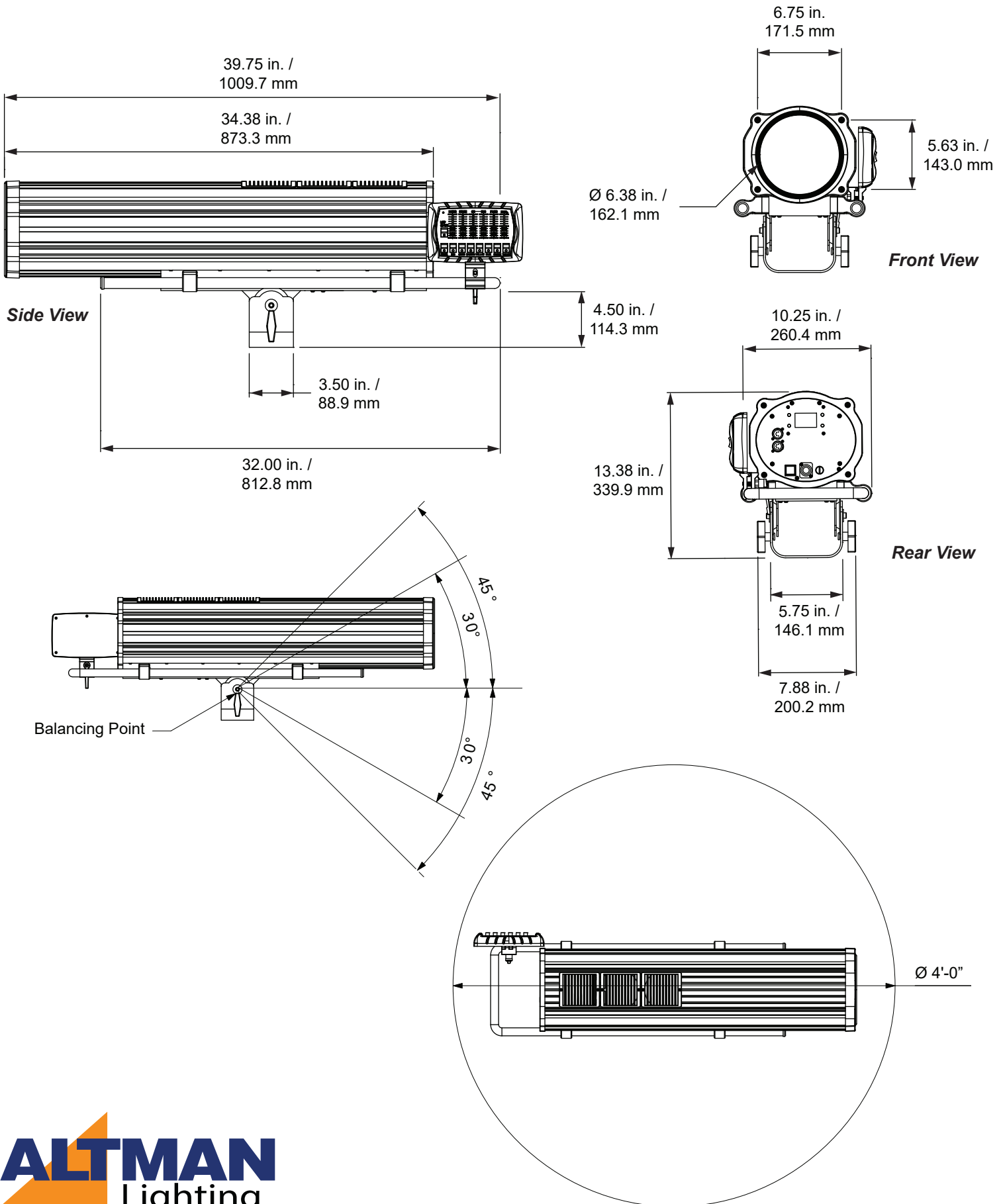

Product Dimensions (Tripod)

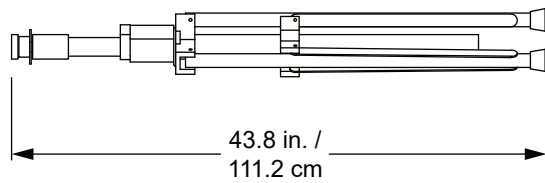
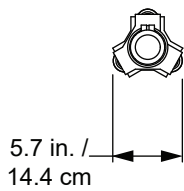
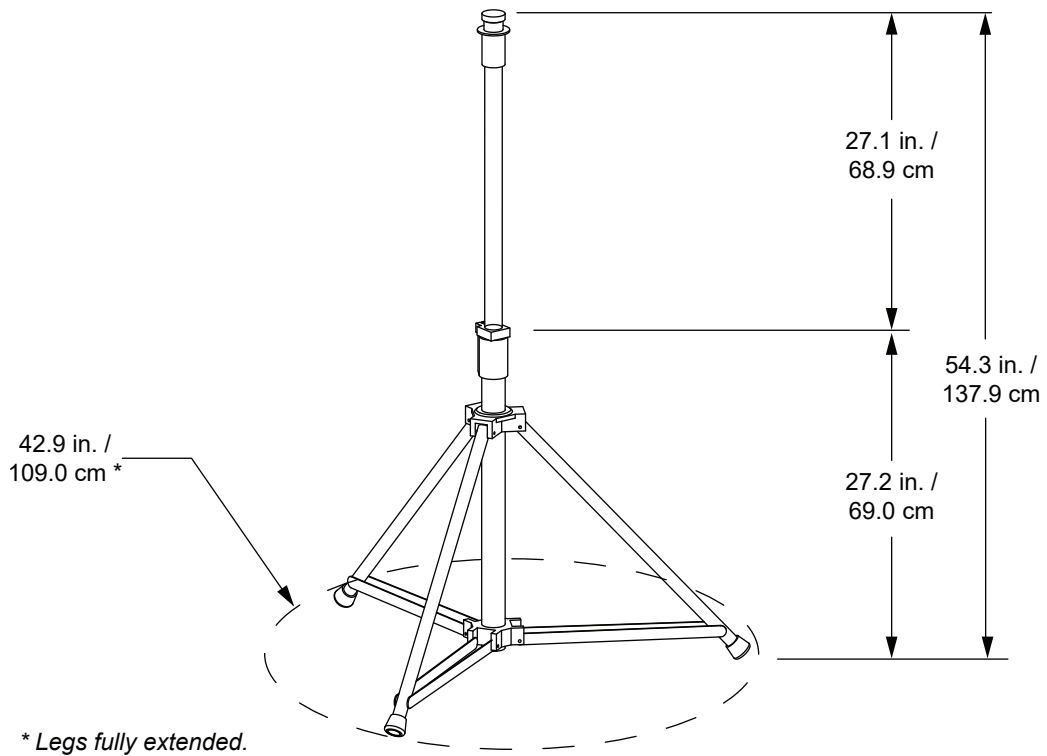

Specifications

Housing: Extruded and die-cast aluminum construction.

Materials: Construction employs all corrosion-resistant materials and hardware.

Light Engine: 778 Watt Cool White Array (7600K)

Beam Lumens: Refer to photometric performance pages

Beam Angle: 7° to 13°

LED Rated Life: LED arrays are rated for > 50,000 hours of operation

Input Voltage: 100 to 240 VAC, 50/60 Hz

Current Draw: 6.48 A at 120VAC / 3.38A at 230VAC

Fuse: T5A, 250V

Quiescent Load: Fans on, Lamp off - 0.51A at 120VAC (61.2 Watts)

Environment: 0 to 45 degrees C (32 to 113 degrees F) with humidity of 5%-95% (non-condensing)

Cooling: Active Fan Cooling: 28dBa (in idle) fans will increase in conjunction with light output up to 37dBa

Weight: Fixture only: 38.3 lbs (17.4 kg)
Tripod only: 12 lbs (5.5 kg)

Fixture Color: Black

Tripod Color: Black

Compliance: cETLus listed and CE marked for indoor use

Control: DMX-512A network or local control via AFS-700 Control Panel (not RDM enabled)

Connectors: Two 5-pin DMX connectors (one input, one output / through)

DMX Channels: 8

Strobe Rates: 1 to 20 Hz

Stand: Three-legged, height adjustable. Height-adjustment lock allows for 360° continuous pan.

Accessories: Accepts standard 7.5-inch accessories in the *optional* front end accessory holder part number AFS-ACCF. Accessories and accessory holder sold separately.

Ordering Information

AFS-700-B, AFS-700 LED Follow Spot, Black*

*Fixture with AFS-700 control panel and tripod stand (AFS-TP). AC power input cable sold separately.

Optional Accessories

PCL-BARE-12-25 PowerCON (blue) to bare end, 25-foot (7.62 m) 20A power input cable

PCL-PBG-12-25 PowerCON (blue) to Edison Male, 25-foot (7.62 m) 20A power input cable

PCL-BARE-12-5 PowerCON (blue) to bare end, 5-foot (1.5 m) 20A power input cable

PCL-2P&G-12-5 PowerCON (blue) to Stage Pin Male, 5-foot (1.5 m) 20A power input cable

PCL-PBG-12-5 PowerCON (blue) to Edison Male, 5-foot (1.5 m) 20A power input cable

PCL-TLG-12-5 PowerCON (blue) to L5-20P Twist Lock Male, 5-foot (1.5 m) 20A power input cable

AFS-ACCF Altman Follow Spot Accessory Face Frame, 7.5 in. x 7.5 in. color filter front end accessory slot (fits AFS-700 or AFS-500 follow spots)

AFS-ECB Altman Follow Spot Accessory, external color boomerang (up to 6 colors - requires AFS-ACCF)

AFS-TP AFS-700 Tripod Stand

AFS-700-CW6 AFS-700 6 pound counter weight for use with the AFS-ECB. Note: One (1) of the AFS-700-CW6's are recommended for balancing the unit when utilizing the AFS-ECB

AFS-700-CW3 AFS-700 3 pound counter weight for use with the AFS-ECB. Note: Two(2) of the AFS-700-CW3's are recommended for balancing the unit when utilizing the AFS-ECB

AFS-700-BH AFS-700 rear mounted handle/counterweight for use with the AFS-ECB

AFS-700-HNDL AFS-700 side mount handle can be mounted anywhere on the frame rail. Side mount handle mounts perpendicular to the frame rail.