

Altman 300*CUS, 450*CUS, & R40*CUS Wood Free Shipping Container

- Up 66' of connector strip w/ pigtails per container.
- Up to 200' of connector strip w/ flush mount connectors per container.
- Up to 60' of continuous R40*CUS Borderlight, and hardware .
- Contains all brackets, hardware, and additional distribution items.
- Shipping supports (pylons) act as stands for easy set up, including attaching hanging brackets.
- Made from 100% corrugated, recyclable and re-puplable.
- Disposable and/or returnable.
- Exempt from many export regulations.
- Stackable 2 high.
- Reduces waste in landfills.
- Reduces end-users disposal costs.
- Using a utility knife, it is easily disposed of in compactors and & bailers.

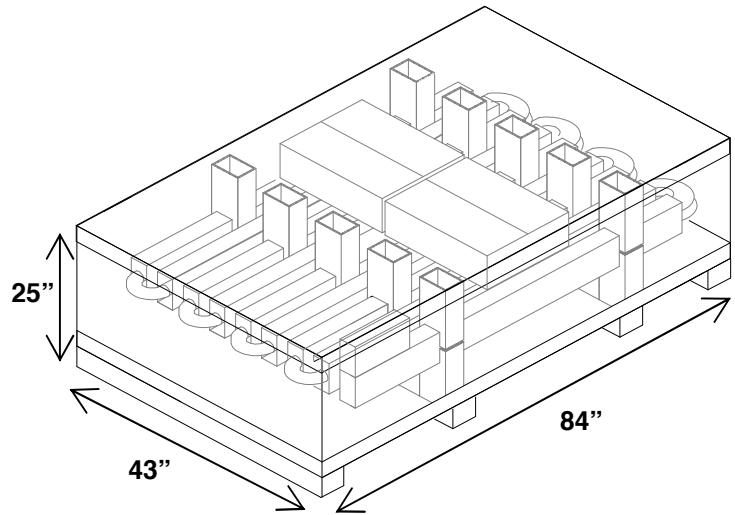

- *Empty Container Weight: 60 Lbs.*
- *Approximate Connector Strip Weight: 5 lbs/ft.*
- *Approximate R40*CUS Borderlight Weight: 7.5 lbs/ft.*

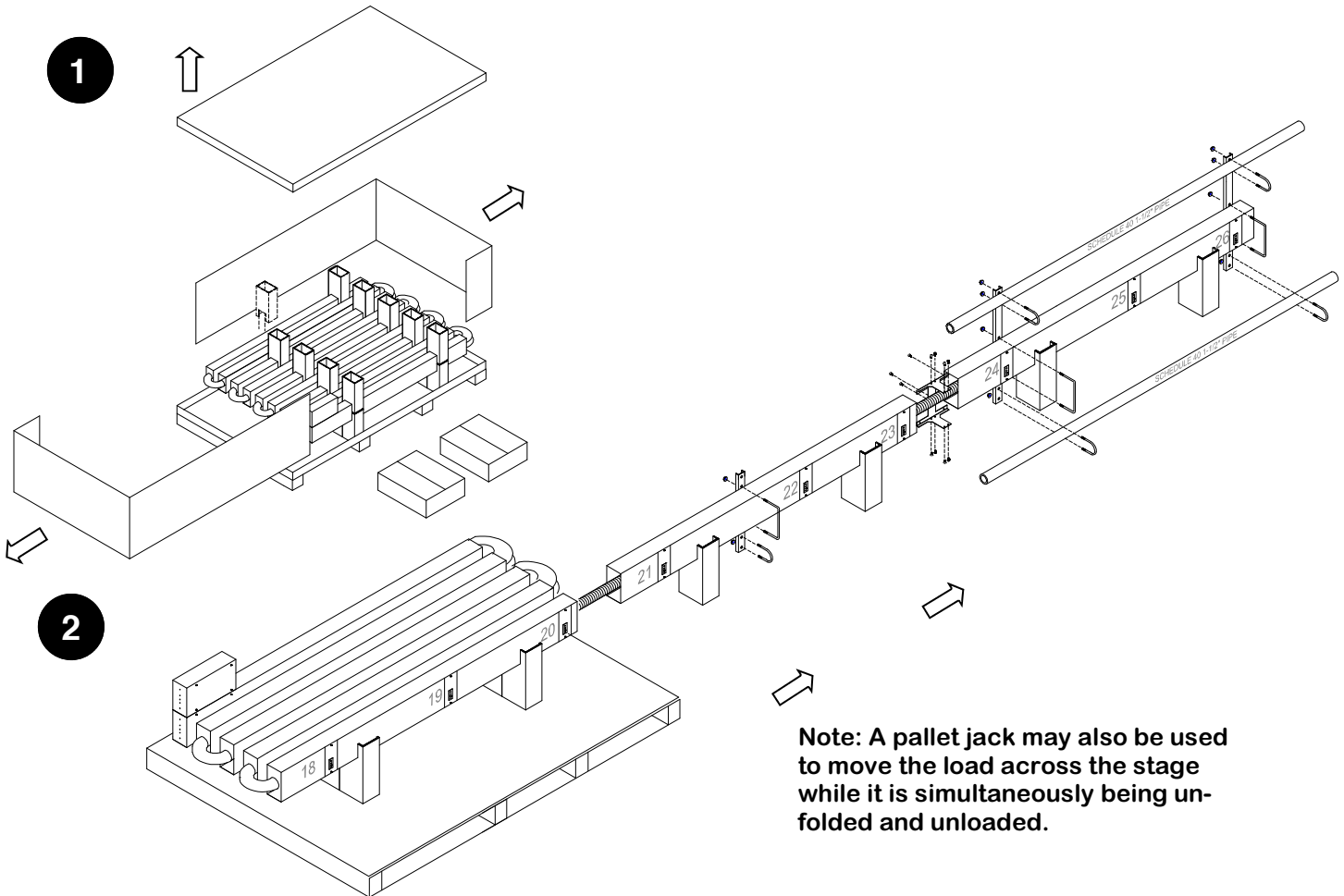

Note: A pallet jack may also be used to move the load across the stage while it is simultaneously being unfolded and unloaded.