



Fixture Type:

A lightweight multi-purpose elliptical reflector floodlight. The 161 scoop produces a very diffuse soft edged beam of 20 feet in diameter at a distance of 10 feet. The 161 is designed to operate high color temperature tungsten halogen lamps. The luminaire is used in theatre and television as both a flood light and a cyclorama fixture. Other uses include photographic and television remote fill light. The scoop is an ideal fixture for color blending and for creating smooth even washes of light.

Specifications subject to change without notice

1 0 0 0 W A T T
 1 6 " S C O O P 1 6 1
 F e a t u r e s

- Heavy spun aluminum construction
- Etched matte aluminum reflector
- Two recessed single contact sockets
- Wire mesh safety screen provided
- Circular color frame available
- Three 36" Teflon lead wires
- U.L. and c.U.L. listed for 1000 watts
- Made in the USA

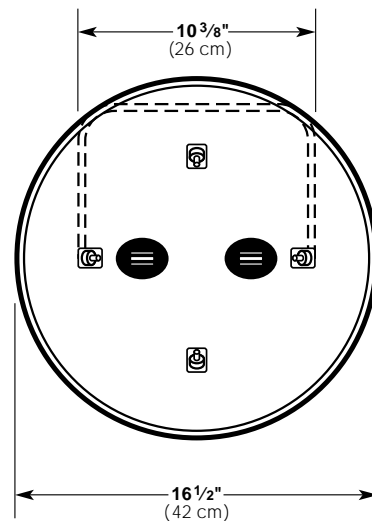
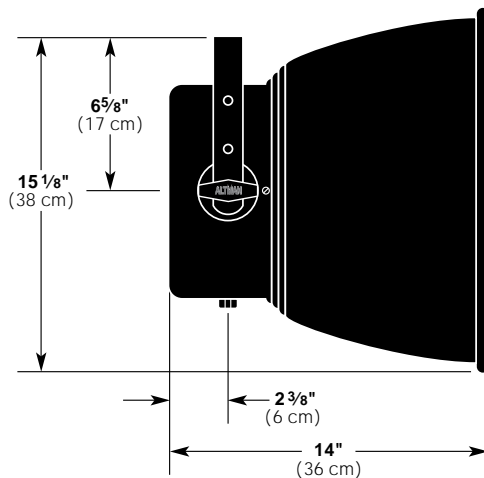

Specifications

Housing: Spun steel construction.

Materials: Construction employs all corrosion-resistant materials and hardware.

Yoke: Rigid flat steel.

Reflector: Etched aluminum, matte finish, elliptical design.

Socket: Recessed single contact, two provided.
Tool free relamping.

Rating: 120/240 volts AC/DC operation
8.3/4.2 amps, 1000 watts maximum.

Cable: 36" Teflon leads encased in black fiberglass sleeving.

Finish: Baked black enamel.

Weight: Approx; 8 ½ lbs. (3.83 kg.)

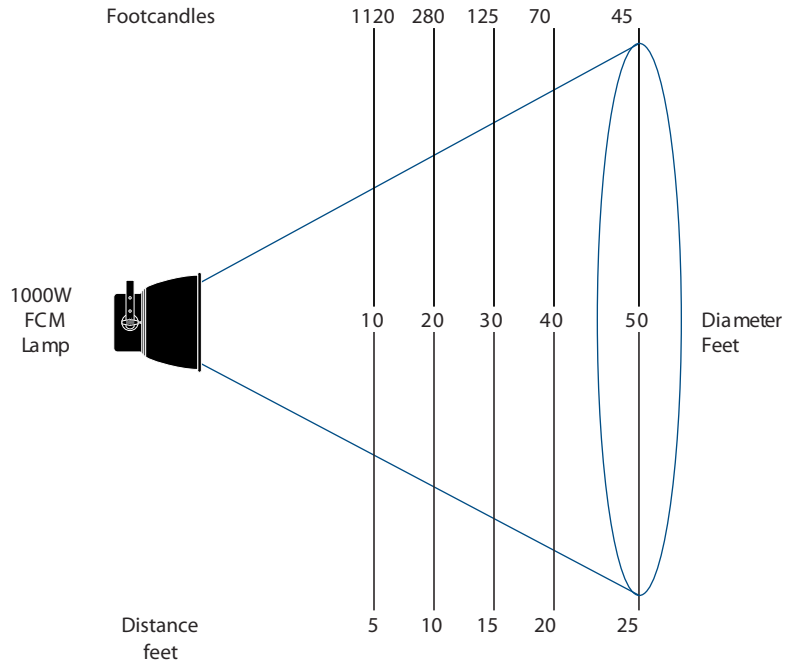

ACCESSORIES Supplied with Luminaire	
161-CF	Color Frame, 16" Diameter w/ Safety Screen

161 SCOOP PERFORMANCE CHART WITH FCM LAMP

Candlepower (Candela)	Beam Angle (Degrees)	Field Angle (Degrees)	Efficiency (%)
28,000	43°	90°	80

ADDITIONAL ACCESSORIES	
510	Malleable Iron Pipe Clamp
SC	Safety Cable with Spring clip

LAMP DATA

Watts	ANSI Code	Manufacturer Lamp Code	Color Temp (°K)	Rated Life (Hours)	Rated Lumens	Correction Factor
500		Q500 T3	3000	2000	10,800	.40
500	FDN	Q500 T3/4	3200	400	12,800	.47
750	DNT	Q750 T3/4	3000	400	19,500	.71
1000	FHM	Q1000 T3/4	3000	400	27,300	.98
1000	FCM	Q1000 T3/4CL	3200	400	28,000	1.00