

SPECTRA PAR 100

WASH LIGHTING

Catalog Numbers

SSPAR-*-**

The Spectra PAR 100 is a 100 Watt par luminaire utilizing red, green, blue and amber LED emitters. Designed for theatrical and architectural applications, the Spectra PAR 100 acts as a true par lighting fixture complete with interchangeable VNSP, NSP, MFL and WFL lenses. The on board power supply allows for direct power input. Data can be easily daisy chained for up to 1000 feet. The Spectra PAR 100 is compatible with both DMX and RDM protocols, and comes complete with a library of pre-programmed single colors and various color mixes. Certified for use in both indoor or outdoor applications.



100 WATT SPECTRA PAR 100 Features

- Available in 4 Standard LED color configurations: *RGBA, RGBW, 3K White or 3K-6K Tunable White[†]*.
- Convection Cooled.
- Available in pipe mount mounting.
- Tool-free exchangeable VNSP, NSP, MFL, WFL & XWFL lenses.
- On-board multi-voltage power supply 100-240VAC.
- Feed through data capabilities using 5-pin XLR connectors.
- Compatible with DMX and RDM protocols.
- Push button addressing.
- Pre-programmed modes for fixed colors, timed color changes and strobes.
- 22 lbs.
- ETL & cETL listed IP65 for outdoor use.
- Made in the USA

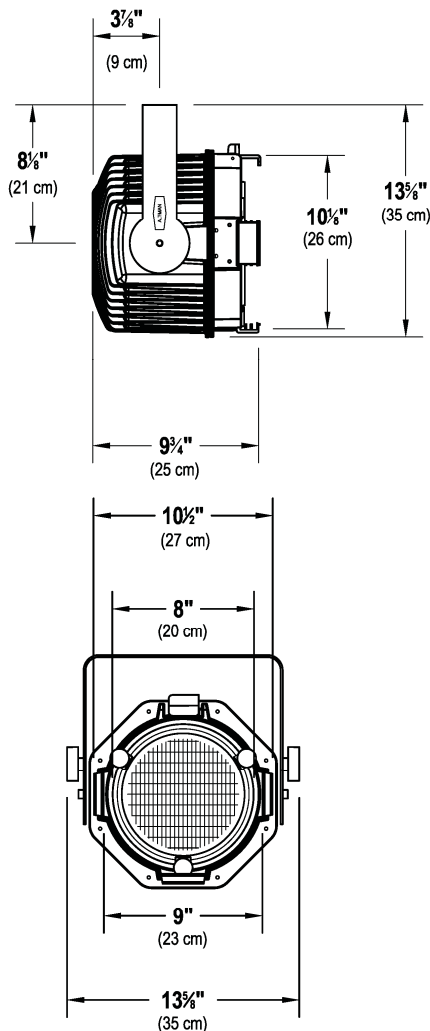

Model	-	LED Array	-	Finish Color
SSPAR100	-	RGBA <input type="checkbox"/>	-	W (White) <input type="checkbox"/>

Project:	Approval Date:
Location:	Fixture Type:

Specifications:

Materials: Construction employs all corrosion-resistant materials and hardware

Housing: Die-case aluminum construction.

Light Engine: Luxeon Rebel LED's- 100 Watts Max at full RGBA

Lenses: Borosilicate glass 8" diameter PAR64

Lens Holder: Fully rotational, provided with three insulated finger tabs. Tool-free changing of lenses. 360° rotation.

Rating: Multi-Voltage; 100-240 volt AC operation

Data Ports: 1 Male & 1 Female 5-Pin XLR cable

Power Cable: 6' total length bare lead.

Finish: Black, White or Silver TGIC polyester, electrostatic application. Custom colors available

Operational Temperature Range:
-20°C (-4° F) to +60°C (140°F)

Weight: Approx. 22 lbs. (9.98 kg)

Accessories:

Model Number	Supplied with the fixture
97-0150	Set of 4 Lenses(VNSP, NSP, MFL, WFL)
SC-36-BK	36" Black Safety Cable w/ Spring Clip
Additional Accessories	
XLR-5-5	5' 5-Pin XLR Extension Cable
XLR-5-10	10' 5-pin XLR Extension Cable
XLR-5-25	25' 5-pin XLR Extension Cable
99-DMX-TERM	In line 5-pin DMX terminator
510	Malleable Iron Pipe Clamp for 3/4"-1 1/2" Pipe
8-BD-4	Four Leaf Barndoor
8-CFB	Black Color Frame 10"x10"
8-SN	Black Snoot
18-0114	Optional XWFL Lens

Basic wiring diagram for SSPAR100-*-** Spectra PAR 100

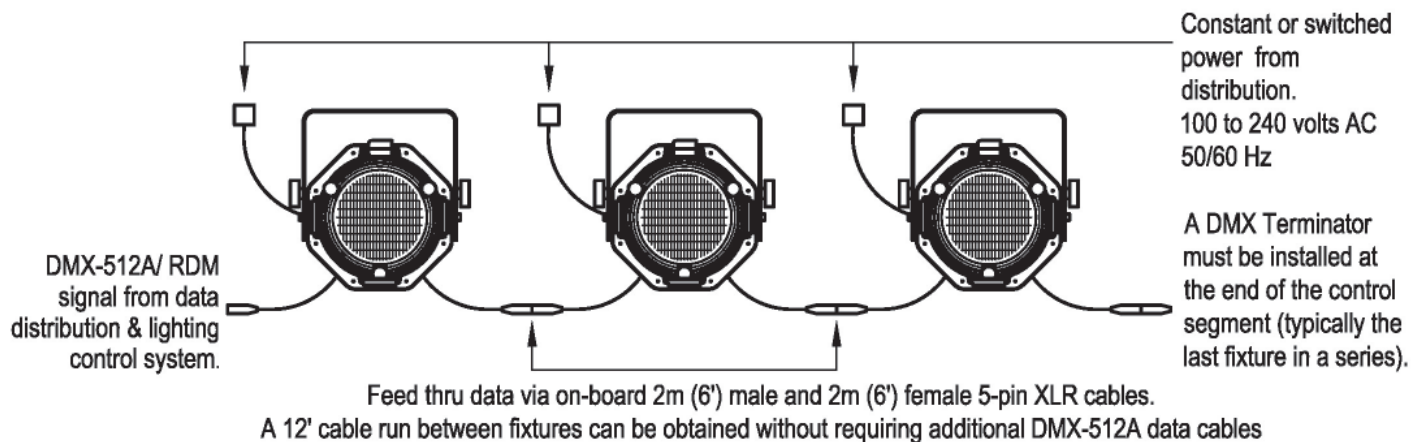

The SSPAR100 Spectra PAR is an IP65 wet location rated fixture and comes with installed male and female Neutrik X-HD Series 5-pin XLR connectors for DMX-512A Input and Output. These connectors are IP65 rated in a mated condition, when correctly installed.

- Panel mount DMX receptacles for exterior applications should be Neutrik MPR-HD series connectors.
- Data extension cables for exterior applications should be fabricated using Neutrik X-HD series connectors for both ends.

Performance per Lens (RGBA array):

VNSP Lens

Throw Distance (d)	10' 3m	15' 4.6m	20' 6.1m	25' 7.6m
Beam Size, (H x V)	1.7' x 1.7' 0.5m x 0.5m	2.5' x 2.5' 0.8m x 0.8m	3.3' x 3.3' 1m x 1m	4.2' x 4.2' 1.3m x 1.3m
Illuminance (fc)	215	96	54	34
Illuminance (lux)	2,316	1,029	579	371

NSP Lens

Throw Distance (d)	10' 3m	15' 4.6m	20' 6.1m	25' 7.6m
Beam Size, (H x V)	2.2' x 2.2' 0.7m x 0.7m	3.3' x 3.3' 1m x 1m	4.4' x 4.4' 1.3m x 1.3m	5.5' x 5.5' 1.7m x 1.7m
Illuminance (fc)	147	65	37	23
Illuminance (lux)	1,579	702	395	253

MFL Lens

Throw Distance (d)	10' 3m	15' 4.6m	20' 6.1m	25' 7.6m
Beam Size, (H x V)	3.27' x 2.5' 1.1m x 0.7m	5.6' x 3.7' 1.7m x 1.1m	7.4' x 4.9' 2.3m x 1.5m	9.3' x 6.1' 2.8m x 1.9m
Illuminance (fc)	81	36	20	13
Illuminance (lux)	871	387	218	139

WFL Lens

Throw Distance (d)	10' 3m	15' 4.6m	20' 6.1m	25' 7.6m
Beam Size, (H x V)	7' x 3.5' 2.1m x 1.1m	10.5' x 5.3' 3.2m x 1.6m	14' x 7.1' 4.3m x 2.1m	17.5' x 8.8' 5.3m x 2.7m
Illuminance (fc)	41	18	10	7
Illuminance (lux)	438	194	109	70

Performance per Lens (3K White array):

VNSP Lens

Throw Distance (d)	10' 3m	15' 4.6m	20' 6.1m	25' 7.6m
Beam Size, (H x V)	1.7' x 1.7' 0.5m x 0.5m	2.5' x 2.5' 0.8m x 0.8m	3.3' x 3.3' 1m x 1m	4.2' x 4.2' 1.3m x 1.3m
Illuminance (fc)	471	209	118	75
Illuminance (lux)	5,068	2,252	1,267	811

NSP Lens

Throw Distance (d)	10' 3m	15' 4.6m	20' 6.1m	25' 7.6m
Beam Size, (H x V)	2.2' x 2.2' 0.7m x 0.7m	3.3' x 3.3' 1m x 1m	4.4' x 4.4' 1.3m x 1.3m	5.5' x 5.5' 1.7m x 1.7m
Illuminance (fc)	364	162	91	58
Illuminance (lux)	3,917	1,741	979	627

MFL Lens

Throw Distance (d)	10' 3m	15' 4.6m	20' 6.1m	25' 7.6m
Beam Size, (H x V)	3.27' x 2.5' 1.1m x 0.7m	5.6' x 3.7' 1.7m x 1.1m	7.4' x 4.9' 2.3m x 1.5m	9.3' x 6.1' 2.8m x 1.9m
Illuminance (fc)	181	80	45	29
Illuminance (lux)	1,948	866	487	312

WFL Lens

Throw Distance (d)	10' 3m	15' 4.6m	20' 6.1m	25' 7.6m
Beam Size, (H x V)	7' x 3.5' 2.1m x 1.1m	10.5' x 5.3' 3.2m x 1.6m	14' x 7.1' 4.3m x 2.1m	17.5' x 8.8' 5.3m x 2.7m
Illuminance (fc)	88	39	22	14
Illuminance (lux)	947	421	237	152