

## SPECTRA CUBE UV

### 50 Watt UV LED WASH UVCUBE

The Spectra Cube UV is a 50 Watt wash luminaire 365nm or 385nm ultraviolet (UV) LEDs. Designed for theatrical and architectural applications with both Smart Track or portable options available. The UVCUBE is convection cooled - without the use of fans - to provide silent, longterm, high-output performance.

The Spectra Cube UV is compatible with DMX and RDM protocols, and comes complete with a library of preprogrammed effects. Units are made for floor, portable, or track mount applications.



#### Product Features:

- 2 LED configurations - either 365nm or 385nm UV LEDs
- Altman Smart Track compatible
- Convection Cooled
- On-board multi-voltage power supply 100-240VAC
- Feed through power and data capabilities
- Compatible with DMX and RDM protocols
- Push button addressing.
- Preprogrammed modes
- Weight: 5 lbs. / 2.3 kg (approximate)
- cETLus listed for indoor use and CE marked
- Made in the USA

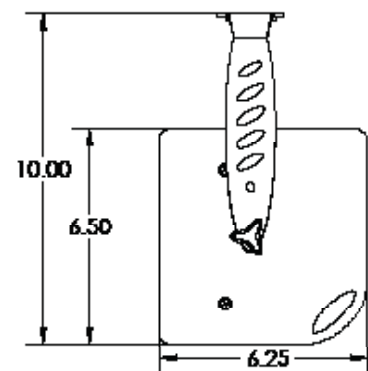
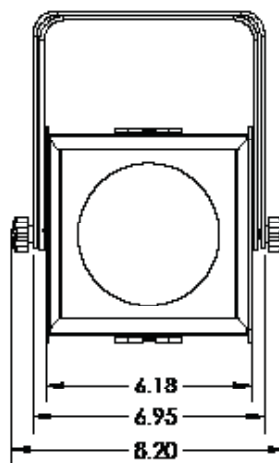
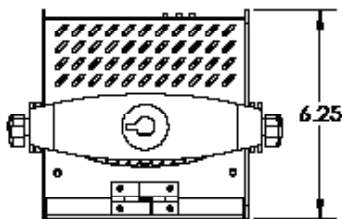

## Specifications

<b>Materials:</b>	Construction is corrosion-resistant materials and hardware.
<b>Housing:</b>	Lightweight aluminum fabrication.
<b>Light Engine:</b>	365nm or 385nm UV LEDs
<b>Rating:</b>	Multi-Voltage; 100-240 VAC operation
<b>Data Ports:</b>	1 Male & 1 Female flush mount 5-Pin XLR
<b>Power Cable:</b>	5-foot, PowerCON with Edison Connector
<b>Finish:</b>	Black or White. Custom colors available - consult factory before ordering.
<b>Weight:</b>	Approx. 5 lbs. (2.3 kg)

## Ordering Information

<b>UVCUBE-*.**</b>	
Model:	Spectra Cube UV LED Luminaire (portable)
<b>UVCUBEY-*.**</b>	
Model:	Spectra Cube UV LED Luminaire for 120V, two-circuit Smart Track
<b>UVCUBEZ-*.**</b>	
Model:	Spectra Cube UV LED Luminaire for 230V, three-circuit Smart Track

\*LEDs: Add the following code for UV Wavelength 65= 365nm or 85 = 385nm

\*\*Body Color: Black (B) or White (W) or Custom (C)\*\*

\*\*\*Consult factory for custom colors.

## Optional Accessories

<b>PCL-PBG-12-5</b>	5-foot 20A PowerCON from 15A Edison Male <i>(Included, portable units)</i>
<b>SC-36-BK</b>	Black Safety Cable with Spring Clip <i>(Included, portable units)</i>
<b>SSCUBE-P95</b>	SSCUBE P95 Acrylic Lens (Included)
<b>510</b>	Malleable Iron Pipe Clamp (2 lbs.)
<b>510-F</b>	Light Duty Flat Steel Pipe Clamp: for 1/4" to 1-1/2" Pipe, Includes 5/16-18 Bolt
<b>SSCUBE-BD4.*</b>	4 Leaf Barn Door
<b>SS-STR-FRP-FF</b>	Filter Frame 5-5/8" X 5-5/8" Fiber Frame
<b>SSCUBE-LV</b>	Spectra Cube Louver - Black
<b>SSCUBE-LSL</b>	SSCUBE Linear Spread Lens
<b>SSCUBE-SL</b>	SSCUBE Spread Lens
<b>SS-STR-LSD-601</b>	Spectra Cube / Strip 60 X 1 Light Shaping Diffuser
<b>SS-STR-LSD-9525</b>	Spectra Cube / Strip 95 X 25 Light Shaping Diffuser
<b>SS-STR-LSD-30</b>	Spectra Cube / Strip 30° Spread Lens
<b>SS-STR-LSD-40</b>	Spectra Cube / Strip 40° Spread Lens
<b>SS-STR-LSD-60</b>	Spectra Cube / Strip 60° Spread Lens

\*Black (B) or White (W) or Custom (C). Consult factory for custom colors.