

SPECTRA CUBE 50 Watt LED WASH

The Spectra Cube is a 50 Watt wash luminaire utilizing red, green, blue and amber or white LED emitters. Designed for theatrical and architectural applications, The Spectra Cube is convection cooled - without the use of fans - to provide silent, longterm, high-output performance. The on-board power supply also allows for direct power and data input which can be daisy chained through 30 units.

The Spectra Cube is compatible with DMX and RDM protocols, and comes complete with a library of pre-programmed single colors to various color mixes. Units are made for floor, portable, or track mount applications.



Product Features:

- Available in 5 Standard LED color configurations: RGBA, RGBW, 3K White, 6K White, or 3K-6K Tunable White *Please Note: The RGBW version utilizes 3K emitters for the white channel. Variants will be considered custom.*
- Altman Smart Track compatible
- Convection Cooled
- On-board multi-voltage power supply 100-240VAC
- Feed through power and data capabilities
- Compatible with DMX and RDM protocols
- Push button addressing.
- Preprogrammed modes
- Kickstand style yoke
- Weight: 5 lbs. / 2.3 kg (approximate)
- cETLus listed for indoor use and CE marked
- Made in the USA

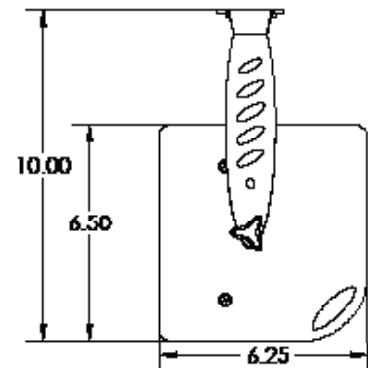
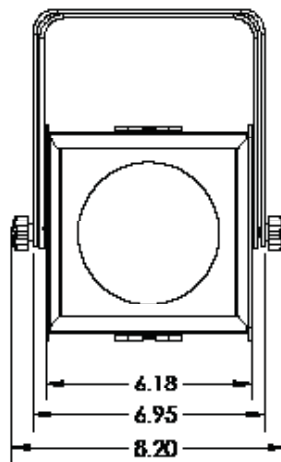
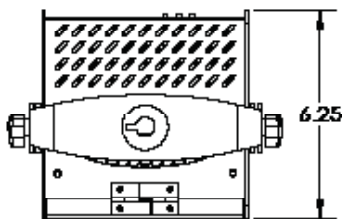

Specifications

Materials: Construction is corrosion-resistant materials and hardware.
Housing: Lightweight aluminum fabrication.
Light Engine: 50 Watts (max.) at Full RGBA
Rating: Multi-Voltage; 100-240 VAC operation
Data Ports: 1 Male & 1 Female flush mount 5-Pin XLR
Power Cable: 5-foot, PowerCON with Edison Connector
Finish: Black or White. Custom colors available - consult factory before ordering.
Weight: Approx. 5 lbs. (2.3 kg)

Ordering Information

SSCUBE-*-**
 Model: Spectra Cube LED Luminaire (portable)
SSCUBEY-*-**
 Model: Spectra Cube LED Luminaire for 120V, two-circuit Smart Track
SSCUBEZ-*-**
 Model: Spectra Cube LED Luminaire for 230V, three-circuit Smart Track
 *LEDs: RGBA, RGBW, 3K White, 6K White, 3K6K Tunable White or Custom (C)^{***}
 Body Color: Black (B) or White (W) or Custom (C)^{**}

^{***}Consult factory for custom LED array. The RGBW version utilizes 3K emitters for the white channel. Variants will be considered custom.
^{****}Consult factory for custom colors.

Optional Accessories

PCL-PBG-12-5 5-foot 20A PowerCON from 15A Edison Male (Included, portable units)
SC-36-BK Black Safety Cable with Spring Clip (Included, portable units)
SSCUBE-P95 SSCUBE P95 Acrylic Lens (Included)
510 Malleable Iron Pipe Clamp (2 lbs.)
510-F Light Duty Flat Steel Pipe Clamp: for 1/4" to 1-1/2" Pipe, Includes 5/16-18 Bolt
SSCUBE-BD4.* 4 Leaf Barn Door
SS-STR-FRP-FF Filter Frame 5-5/8" X 5-5/8" Fiber Frame
SSCUBE-LV SS-STR-LSD-601 Spectra Cube Louver - Black
 Spectra Cube / Strip 60 X 1 Light Shaping Diffuser

SS-STR-LSD-9525 Spectra Cube / Strip 95 X 25 Light Shaping Diffuser
SS-STR-LSD-30 Spectra Cube / Strip 30° Spread Lens
SS-STR-LSD-40 Spectra Cube / Strip 40° Spread Lens
SS-STR-LSD-60 Spectra Cube / Strip 60° Spread Lens

*Black (B) or White (W) or Custom (C). Consult factory for custom colors.

NOTE:
 For field diameter at any distance, multiply distance by 0.35.

PHOTOMETRICS (RGBA)				
Throw Distance (d)	10' / 3m	15' / 4.6m	20' / 6.1m	25' / 7.6m
Field Size (HxV)	3.5' x 3.5' 1.1m x 1.1m	5.3' x 5.3' 1.6m x 1.6m	7.1' x 7.1' 2.1m x 2.1m	8.8' x 8.8' 2.7m x 2.7m
Illuminance (fc)	108	48	27	17
Illuminance (lux)	1,158	515	289	185

PHOTOMETRICS (3K White)				
Throw Distance (d)	10' / 3m	15' / 4.6m	20' / 6.1m	25' / 7.6m
Field Size (HxV)	3.5' x 3.5' 1.1m x 1.1m	5.3' x 5.3' 1.6m x 1.6m	7.1' x 7.1' 2.1m x 2.1m	8.8' x 8.8' 2.7m x 2.7m
Illuminance (fc)	236	105	59	38
Illuminance (lux)	2,534	1,126	633	405