

PHX3.5 LED ZOOM

The 15°-35° and 30°-55° PHX LED Zoom Spot are state of the art luminaires in function, style, and efficiency. These zoom spot profiles have been designed and engineered with a number of innovative details and features enhancing versatility and efficiency without sacrificing performance.

PHX 3.5 is a 340 Watt (RGLB) Red, Green, Blue, and Lime Zoom Spot outputting just over 10,000 Lumens which makes it a true front of house luminaire. A locking 360° rotating barrel help you keep the artistic part of your fixtures' focus intact with virtually no light leak.

The PHX3.5 features an RGLB array that won't force users to choose between deep saturates and gorgeous pastels; you'll be able to achieve brilliant whites ranging from 2700K all the way up to 10,000K along with deep golds, burning reds and springtime lavenders.

These new and innovative options are what makes the PHX LED Zoom Spot ideal for theaters, special events, television studios, or wherever superior, energy efficient lighting performance is required.



PHX3.5 30-55 Degree Zoom

Product Features:

- Red, Green, Blue, Lime LED Engine
- 360-degree rotating barrel
- Positive locking double-clutch fixture body
- Heat resistant Plano-Convex lensing
- Die-cast aluminum and sheet metal fabrication
- Wide accessory slot with sliding cover for motorized pattern devices or optional iris
- Color frame, C-Clamp, soft focus pattern holder, safety cable and 5 foot PowerCON included
- PowerCON in and out for daisy-chaining units
- 100 to 240 VAC 50/60 Hz operation
- Available standard in Black or White
- Yoke made from rigid flat steel with dual locking handles, two mounting positions and indexed tilt angle markings
- DMX512 in/thru via 5-pin XLR connector
- Compatible with DMX 512 and RDM protocols
- Multiple on-board control options: color fades and strobes
- User friendly control interface
- Console free stand alone Player Mode
- Multiple Dimming Curves
 - Logarithmic
 - Square Law
 - Linear
- Dimming - Smoothing Mode
- 8-bit or 16-bit virtual dimming engine provides smooth, high quality fades and minimizes color shift during dimming
- Four different control settings of:
 - 16-Bit Mode, Master Channel On (10 DMX Channels)
 - 16-Bit Mode, Master Channel Off (8 DMX Channels)
 - 8-bit Mode, Master Channel On (5 DMX Channels)
 - 8-bit Mode, Master Channel Off (4 DMX Channels)
- 27.15 lbs. (12.34 kg.)
- cETLus, CE and PSE (IP20 Rated for indoor use)
- Assembled in the USA
- Five (5) year and one (1) day warranty
- No cost technical support for the life of your product



Note: all photometric data is taken after a 90 minute warm up time period with all colors at full intensity.

Photometric Performance - PHX 3.5 RGBL Luminaires with 15-30 Degree Zoom Lens (at Full Intensity)

Narrow - 12800 Lumens

Throw Distance (d)	10' 3.05m	15' 4.57m	20' 6.09m	25' 7.62m	30' 9.14m	35' 10.67m	40' 12.19m	45' 13.72m	50' 15.24m	55' 16.76m
Beam Size Diameter	2'-9" 0.85m	3'-11" 1.19m	5' 1.54m	6'-2" 1.89m	7'-4" 2.24m	8'-6" 2.58m	9'-7" 2.93m	10'-9" 3.28m	11'-11" 3.63m	13' 3.97m
Illuminance = fc (Illuminance = lux)	2916 (31387)	1296 (13950)	729 (7847)	467 (5022)	324 (3487)	238 (2562)	182 (1962)	144 (1550)	117 (1255)	96 (1038)

Medium - 11179 Lumens

Throw Distance (d)	10' 3.05m	15' 4.57m	20' 6.09m	25' 7.62m	30' 9.14m	35' 10.67m	40' 12.19m	45' 13.72m	50' 15.24m	55' 16.76m
Beam Size Diameter	4'-3" 1.30m	6'-2" 1.88m	8'-1" 2.46m	9'-11" 3.03m	11'-10" 3.61m	13'-9" 4.18m	15'-7" 4.76m	17'-6" 5.34m	19'-5" 5.91m	21'-3" 6.49m
Illuminance = fc (Illuminance = lux)	1388 (14940)	617 (6640)	347 (3735)	222 (2390)	154 (1660)	113 (1220)	87 (934)	69 (738)	56 (598)	46 (494)

Wide - 11448 Lumens

Throw Distance (d)	10' 3.05m	15' 4.57m	20' 6.09m	25' 7.62m	30' 9.14m	35' 10.67m	40' 12.19m	45' 13.72m	50' 15.24m	55' 16.76m
Beam Size Diameter	5'-10" 1.79m	8'-6" 2.60m	11'-3" 3.42m	13'-11" 4.24m	16'-7" 5.05m	19'-3" 5.87m	21'-11" 6.69m	24'-7" 7.50m	27'-3" 8.32m	29'-11" 9.14m
Illuminance = fc (Illuminance = lux)	960 (10332)	427 (4592)	240 (2583)	154 (1653)	107 (1148)	78 (843)	60 (646)	47 (510)	38 (413)	32 (342)

Photometric Performance - PHX 3.5 RGBL Luminaires with 30-55 Degree Zoom Lens (at Full Intensity)

Narrow - 10272.6 Lumens

Throw Distance (d)	10' 3.05m	15' 4.57m	20' 6.09m	25' 7.62m	30' 9.14m	35' 10.67m	40' 12.19m	45' 13.72m	50' 15.24m	55' 16.76m
Beam Size Diameter	5'-6" 1.69m	8' 2.45m	10'-7" 3.22m	13'-1" 3.98m	15'-7" 4.75m	18'-1" 5.52m	20'-7" 6.28m	23'-2" 7.05m	25'-8" 7.82m	28'-2" 8.58m
Illuminance = fc (Illuminance = lux)	850 (9149)	378 (4066)	213 (2287)	136 (1464)	94 (1017)	69 (747)	53 (572)	42 (452)	34 (366)	28 (302)

Medium - 11065.5 Lumens

Throw Distance (d)	10' 3.05m	15' 4.57m	20' 6.09m	25' 7.62m	30' 9.14m	35' 10.67m	40' 12.19m	45' 13.72m	50' 15.24m	55' 16.76m
Beam Size Diameter	7'-1" 2.16m	10'-5" 3.17m	13'-8" 4.17m	17' 5.18m	20'-3" 6.18m	23'-7" 7.19m	26'-11" 8.19m	30'-2" 9.20m	33'-6" 10.20m	36'-9" 11.21m
Illuminance = fc (Illuminance = lux)	540 (5813)	240 (2583)	135 (1453)	86 (930)	60 (646)	44 (474)	34 (363)	27 (287)	22 (233)	18 (192)

Wide - 11015.30 Lumens

Throw Distance (d)	10' 3.05m	15' 4.57m	20' 6.09m	25' 7.62m	30' 9.14m	35' 10.67m	40' 12.19m	45' 13.72m	50' 15.24m	55' 16.76m
Beam Size Diameter	8'-10" 2.68m	13' 3.95m	17'-1" 5.22m	21'-3" 6.48m	25'-5" 7.75m	29'-7" 9.01m	33'-9" 10.28m	37'-10" 11.54m	42' 12.81m	46'-2" 14.08m
Illuminance = fc (Illuminance = lux)	352 (3785)	156 (1682)	88 (946)	56 (606)	39 (421)	29 (309)	22 (237)	17 (187)	14 (151)	12 (125)

PHX 3.5 RGL - 15°-35° Zoom Profile Spot

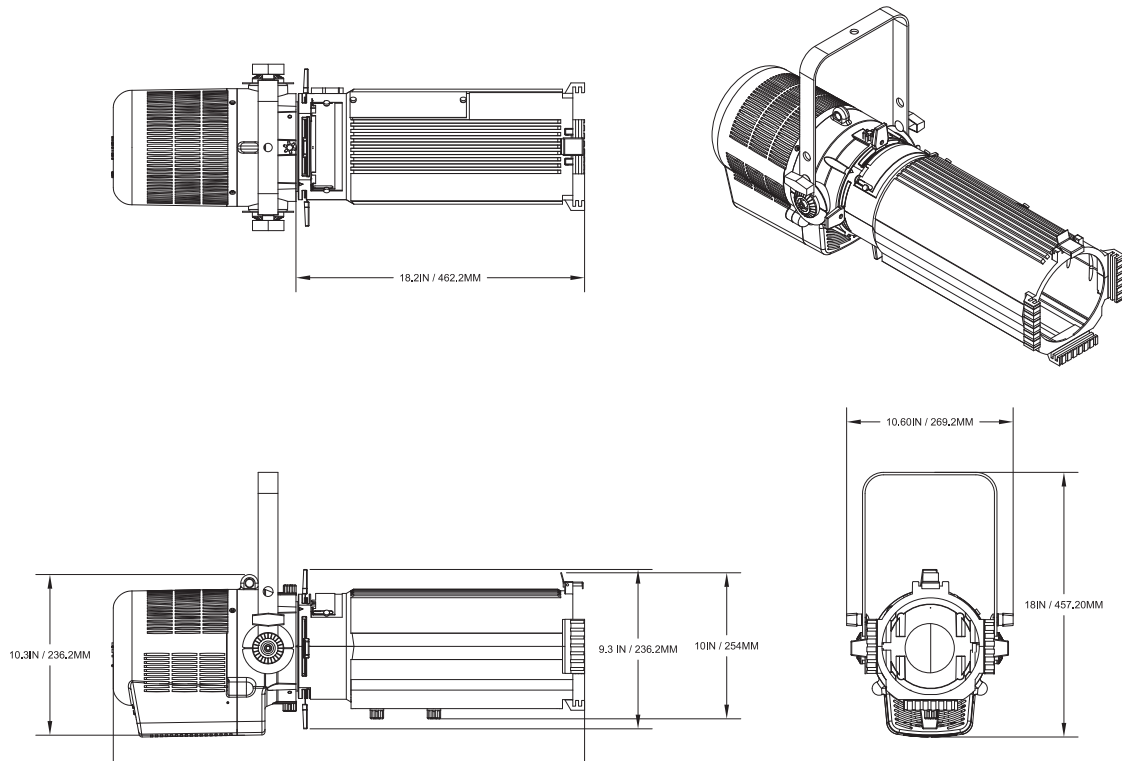

PHX 3.5 RGL - 30°-55° Zoom Profile Spot

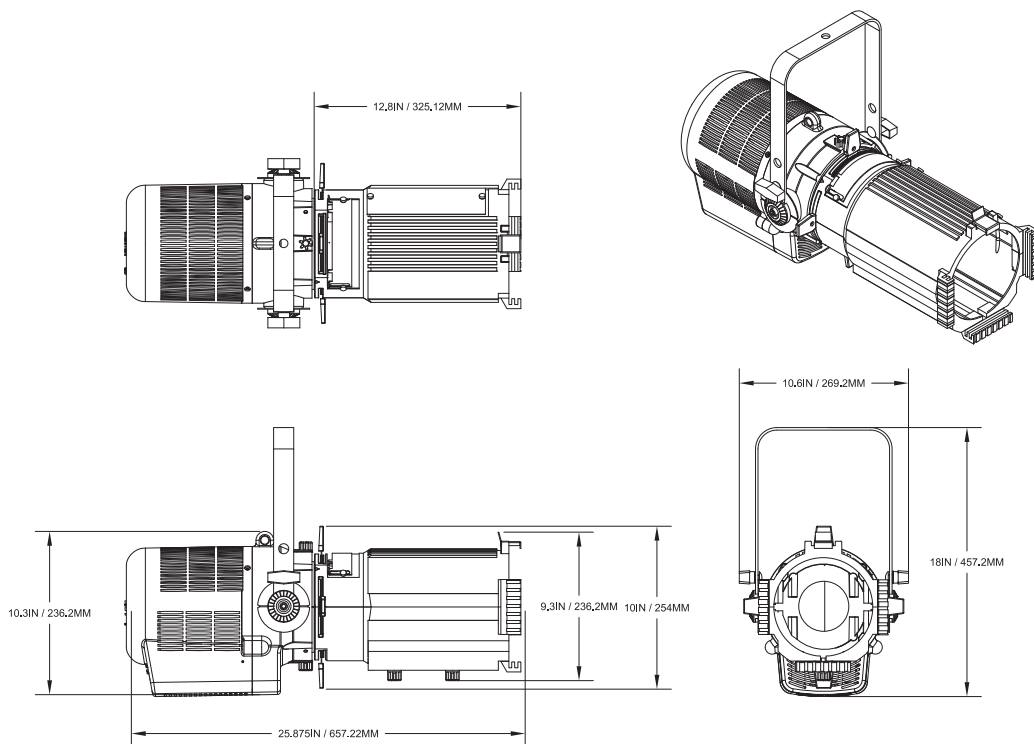

Specifications

Materials: Corrosion-resistant materials and hardware
Control: DMX/RDM
Light Engine: Available in RGBL
Beam Lumens: See photometrics
Rated LED Life: Array rating >50,000 hours to L70
Input Voltage: 100-240 VAC 50/60 Hz
Watts: 340
Current Draw: 1.25A at 120VAC / 0.65A at 230VAC
Quiescent Load: 0.087 AMP (10.54 Watts) @ 120 VAC*
 0.045 AMP (10.54 Watts) @ 240 VAC*
 *Fan and display off
Power Factor ≥ 0.95
Power Through: Up to 5 Units at 120VAC*
 Up to 10 units at 230 VAC*
 * Recommended Power linking of units via powercon connection.
LED Engine Cooling: Convection, passive, silent
Environment: 0 - 40°C (32 - 104°F) with humidity of 5-95% non-condensing
Weight: 26.55 lbs. (12.34 kg.)
Body Color: Black or White
Compliance: cETLus, CE and PSE (IP20 Rated for indoor use)
Warranty: Five (5) years and One (1) day
Support: Supported Forever - free phone and online tech support for the life of your product.

DMX VALUES FOR WHITE SETTINGS:

	RED	GREEN	BLUE	LIME	WATTS
3200K	100%	73%	63%	100%	193W
4200K	100%	88%	72%	100%	230W
5600K	100%	96%	84%	100%	267W

Note: There are many aftermarket accessories for Altman Lighting products available through third-party suppliers. When considering these aftermarket accessories, we suggest that you consult with your Altman Regional Sales Manager beforehand regarding capability and effects on product performance.



Ordering Information

PHX3.5-(LED ARRAY)-(LENS TYPE)-(FINISH COLOR)

Model PHX3.5 (PHX3.5 340W LED Zoom Profile)
LED Array: RGBL (RGBL)
Lens Type: 15Z (15°-35° zoom) or 30Z (30°-55° zoom)
Body Color: Black (B) or White (W)

Note: Each unit ordered includes a 7-1/2" x 7-1/2" Color Frame (6-CFB), C-Clamp (510), 36" Black Safety Cable (SC-36-BK), PHX Zoom Soft Focus Lens with B-Size Pattern Holder (PHXZ-SFLGSB), and 5-Foot AC Cable PowerCON to Edison (PCL-PBG-12-)*

Accessories

- 6-CFB** Color Frame, 7-1/2" x 6-1/2"
- 510** Malleable Iron Pipe Clamp
- 510-HD** Heavy Duty Malleable Iron Pipe Clamp
- SC-36-BK** 36" Black Safety Cable with Spring Clamp
- 6-DN** 7-1/2" x 7-1/2" Donut, Black with 3" Hole
- PDII** PHX Drop In Iris
- PHXZ-SFLGSB** PHX Zoom Soft Focus lens with B Size Pattern Holder
- PHXZ-PHGSB** B Size Steel Pattern Holder (86mm OD / 64.5mm IA)
- PHXZ-PHGSB-3T** B Size Steel Pattern Holder (86mm OD / 64.5mm IA) 3 Tab Style
- PHX-PHISB** B Size Steel Pattern Holder (86mm OD / 64.5mm IA) for Iris Slot
- PHX-PHISA-GLS** A Size Glass Pattern Holder (100mm OD / 75mm IA) for Iris Slot
- PHX-PHISB-GLS** B Size Glass Pattern Holder (82mm OD / 64.5mm IA) for Iris Slot
- PHX-PHIS86-GLS** B Size Glass Pattern Holder (86mm OD / 64.5mm IA) for Iris Slot
- PCL-PBG-12-*** 5' 20A PowerCON with Parallel Blade U Ground (Edison)
- PCL-2P&G-12-5-*** 5' 20A PowerCON with 2P&G Stage Pin Connector, Male
- PCL-TLG-12-5-*** 5' 20A PowerCON with L5-20P Twist Locking Ground Connector, Male
- PCL-BARE-12-5-*** 5' 20A PowerCON with Bare End Lead

*Note: *=W for White Cable, Black is standard and no suffix is required*



Altman Lighting +1 303 500-7072
 1400 East 66th Avenue sales@altmanlighting.com
 Denver, CO 80229 USA support@altmanlighting.com

29 June 2022 © 2022 Altman Stage Lighting, Inc.
 All specifications, descriptions, information, design, etc. contained in this document are subject to change without prior notice. All rights reserved. 49-0213