

# RECESSED CHALICE 50W LED DOWNLIGHT

The 50W Recessed Chalice from Altman Lighting is a LED architectural downlight designed for permanent installation and energy savings. Offering all of the benefits and longevity of an LED luminaire, changing lamps in your fixtures has now become a thing of the past.

Adding a fixture into a DMX system control system is easy with the simple three-button DMX addressing that is easily accessible from the bottom of the fixture - set it once and enjoy a smoothly integrated and energy efficient illumination solution for your area of choice.

The 50W Recessed Chalice fixture is able to be controlled by your DMX Control console & architectural control system; for facilities without a DMX control system the 50W Recessed Chalice is also available in a single color channel mains dimmable fixture.

## **Product Features:**

- 50W LED driver
- 5 interchangeable lenses
- DMX or Mains Dimmable (note, mains dimmable available in a single color LED only)
- Push Button DMX Addressing and RDM compatibility
- DMX Pass through
- 8-bit or 16-bit selectable DMX modes
- Available in white, black or custom colors (trim ring)
- cETLus listed for indoor applications
- Proudly made in the USA
- Five (5) year and one (1) day warranty
- No cost technical support for the life of your product



*Recessed Chalice 50*

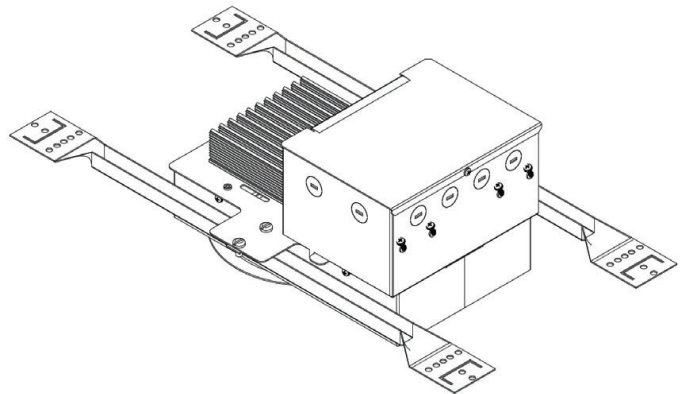

*Recessed Chalice 50 with supports*



# Dimensions

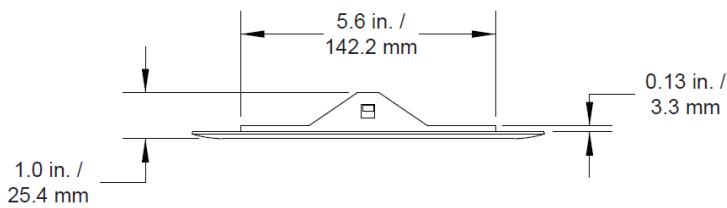
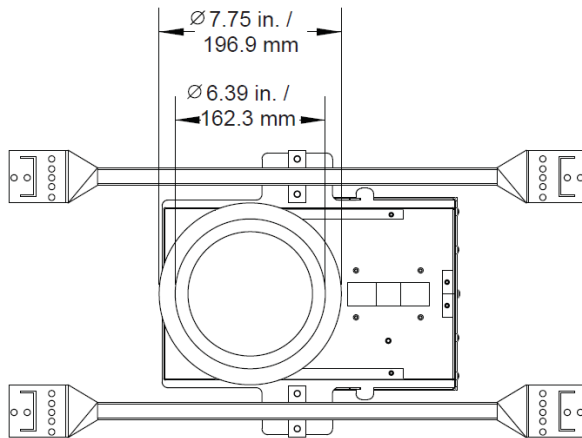
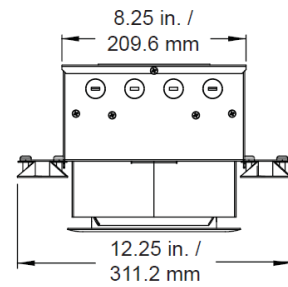
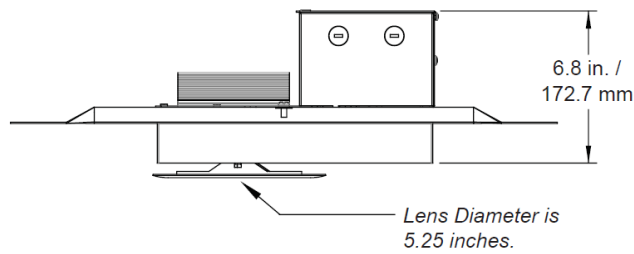
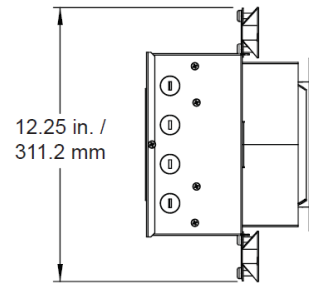
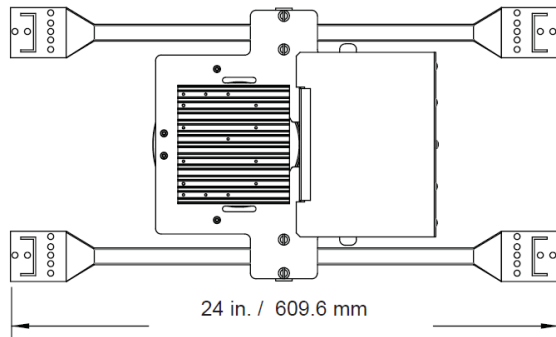

## Specifications

<b>Materials:</b>	Corrosion-resistant materials and hardware
<b>Control:</b>	Mains dimmable or DMX/RDM
<b>Light Engine:</b>	DMX Models: 100W LED Array - Available in 3000K to 6000K Tunable White, RGBA, RGBW, Dim to Warm and custom arrays (consult factory before ordering). <i>Mains Dimmable Models:</i> 100W LED Array - Available in with single color, custom arrays only. Consult factory before ordering.
<b>Lumens:</b>	Maximum 1515
<b>Rated LED Life:</b>	Array rating >50,000 hours to L70
<b>Input Voltage:</b>	DMX Models: 100-240 VAC 50/60 Hz
<b>LED Engine Cooling:</b>	Convection, passive
<b>Environment:</b>	0 - 40°C (32 - 104°F) with humidity of 5-95% non-condensing)
<b>Weight:</b>	12 lbs. (5.44 kgs.)
<b>Compliance:</b>	cETLus listed for indoor use
<b>Warranty:</b>	Five (5) years and One (1) day
<b>Support:</b>	Supported Forever - free phone and online tech support for the life of your product.

### NOTES:

Noise levels on mains dim luminaires are subject to the dimming/switching systems in which they are wired. Electrical systems displaying harmonics may increase the dB Noise output of the luminaire.

Do not connect more than four (4) mains dim luminaires to the same dimmer. Connecting more than four luminaires to the same dimmer will result in undesired low-end dimmer response. Dimmer must be sized appropriately to handle luminaire load.

Maximum number of DMX controlled fixtures is as per installed breaker current breaking capacity and inrush current capacity.

## Ordering Information

**CDR50-(MOUNTING)-LED ARRAY)-(BODY COLOR)-(CONTROL)-(VOLTAGE)**

<b>Model:</b>	CDR50 Chalice Recessed LED Luminaire
<b>LED Array:</b>	(RGBA), (RGBW), Tunable White (3K6K), Dim to Warm - 3/4:3k 1/4:Amber (DTW), or Custom (C)*
<b>Trim Ring Color:</b>	Black (B) or White (W) or Custom (C)*
<b>Control:</b>	DMX Control (D) or Mains Dimmable (M)**
<b>Voltage:</b>	120 (120VAC), 220 (220VAC)

### NOTES:

\*Consult factory before ordering.

\*\*Mains Dimmable models are not available for RGBA, RGBW, or tunable white LED fixtures. Only available with a single color, custom LED array (for custom LED arrays, consult factory before ordering).

## Optional Accessories

<b>18-CDR50-20</b>	20°, 5.25" diameter Acrylic Lens
<b>18-CDR50-30</b>	30°, 5.25" diameter Acrylic Lens
<b>18-CDR50-40</b>	40°, 5.25" diameter Acrylic Lens
<b>18-CDR50-60</b>	60°, 5.25" diameter Acrylic Lens
<b>18-CDR50-P95</b>	22°, 5.25" diameter Diffusion Lens

### Notes:

The above lenses are for use with the CDR50 fixtures only and are not interchangeable with the CDP series luminaires.

When using diffusers (20°, 30°, 40°, 60° and P95) please allow for a minimum throw distance of 10'-0" (approximately 3m) for color uniformity.